

INSTALLATION INSTRUCTIONS

COMMERCIAL SECTIONAL DOORS



Amarr 2002/2012/2022	Amarr 2743
Amarr 2402/2412/2422	Amarr 2747
Amarr 2502/2512/2522	Amarr 3040
Amarr 2042	Amarr 3502
Amarr 2432	Amarr 3552
Amarr 2442	Amarr 3582
Amarr 2731	Amarr AX3592 (residential & commercial)
Amarr 2732	Amarr Vista VI1000 (residential)
Amarr 2741	Amarr Horizon HI1000 (residential)
Amarr 2742	

For Professional Dealer Installation

165 Carriage Court
Winston-Salem, NC 27105
www.amarr.com

For replacement documents, parts or questions about installation, call 1-800-503-DOOR (3667)

Table of Contents

Page 2 - Safety Information and Warnings
 Page 4 - Required Parts
 Page 6 - Jamb and Spring Pad
 Page 8 - Installing Hardware
 Page 10 - Installing Sections - Bottom / Vertical Track
 Page 12 - Installing Sections - Intermediate
 Page 14 - Installing Horizontal Track
 Page 16 - Installing Sections - Top
 Page 18 - Strut Installation and Schedule
 Page 20 - Universal End Bearing Plate Installation
 Page 22 - Torsion Spring Growth
 Page 23 - Torsion Spring Installation
 Page 25 - Torsion Spring Mount Types
 Page 27 - Track Hanger Installation
 Page 29 - Slide Lock Installation
 Page 30 - Perimeter Seal Installation
 Page 31 - Low Head Room Torsion to the Front Installation
 Page 33 - Low Head Room Torsion to the Rear Installation
 Page 35 - High Lift Installation
 Page 37 - Vertical Lift Installation
 Page 39 - Rapid Install Vertical Lift Installation
 Page 40 - Follow the Roof Pitch Installation
 Page 42 - Shaft Coupler Installation
 Page 43 - Offset Trolley Operator Application and Installation
 Page 44 - 3552 & Vista VI1000 Strut Installation and Schedule
 Page 45 - 3582 & Horizon HO1000 Strut Installation and Schedule

Installer: After installation is complete, attach all warning labels and tags where indicated and place this manual near the door.

Date of installation:

Installed by:

Notes:

READ THE ENTIRE INSTRUCTIONS BEFORE USING THIS PRODUCT. FAILURE TO FOLLOW THE INSTRUCTIONS AND SAFETY PRECAUTIONS IN THIS DOCUMENT CAN RESULT IN SERIOUS INJURY OR DEATH. KEEP THE INSTRUCTIONS IN A SAFE LOCATION FOR FUTURE REFERENCE. ALSO READ THE OWNERS MANUAL (PROVIDED SEPARATELY).

Installation Instructions are available at no charge from Amarr, call toll free 1.800.503.DOOR (3667), email: ask@amarr.com, or online at www.amarr.com.



Overview of Safety Guidelines and Your Responsibilities:

1. Overhead garage doors are large, heavy objects that move with the help of springs under high tension and electric motors. Since moving objects, springs under tension, and electric motors can cause injuries, your safety and the safety of others depends on you thoroughly reading and understanding these instructions and the owner's manual (provided separately). If you have questions or do not understand the information presented, call 1.800.503.DOOR (3667).
2. Most garage door incidents are caused by failure to observe basic safety rules or precautions. An incident can often be avoided by recognizing potentially hazardous situation before an incident occurs. A person must be alert to potential hazards. This person should also have the necessary training, skills and tools to install the door properly.
3. This is the safety alert symbol. It is used to alert you to potential personal injury hazards. The meaning of this safety alert symbol is as follows: **Attention! Become Alert! Your safety may be at risk.** The message that appears under the warning explains the hazard and can be either written or pictorially presented.
4. Obey all safety messages that follow the Safety Alert symbol to avoid possible personal injury or death. The hazards are identified by the "Safety Alert Symbol" and followed by a "signal word" such as "WARNING" or "CAUTION". For your convenience the signal words and definitions are provided below:



- **WARNING:** Indicates a hazardous situation which, if not avoided, result in death or serious bodily injury.



- **CAUTION:** Indicates a hazardous situation which, if not avoided, could result in minor or moderate bodily injury.



- **NOTICE:** Indicates a situation that could result in equipment related damage.



- **SAFETY SYMBOLS:** The following safety symbols appear throughout this manual to alert you to important safety hazards and precautions to prevent injury.



OVERHEAD CRUSH
HAZARD



WEAR SAFETY
GLASSES



WEAR
HARD HAT



READ THIS
MANUAL



WEAR
GLOVES



PROHIBITION

5. Every possible circumstance that might involve a potential hazard cannot be anticipated. The warnings in this publication and on the product are, therefore, not all inclusive. If a tool, procedure, work method or operating technique that is not specifically recommended by Amarr Company is used, you are responsible that it is safe for you and for others. You are responsible that the product will not be damaged or be made unsafe by the operation, lubrication, maintenance or repair procedures that you choose.

General Safety Guidelines:

- *DO NOT permit children to operate the garage door or door controls. Severe or fatal injury could result should a child become entrapped between the floor and the door.*
- *DO NOT attempt to adjust, repair or alter any part of the garage door, especially to springs, spring brackets, bottom corner brackets, fasteners, counterbalance lift cables or supports. Installation and repair work MUST be performed by a trained garage door technician.*
- *RED fasteners must be used where required. These fasteners hold parts which are under extreme tension. RED fasteners are not to be loosened or removed.*
- *DO NOT stand or walk under a moving garage door. Keep door fully in view and free of obstructions when operating.*
- *DO NOT place fingers or hands into open section joints or track when garage door is moving.*
- *REMOVE pull down ropes and disable locks on electrically operated garage doors.*
- *ALWAYS wear work gloves and safety glasses during installation.*
- *INSPECT doors and hardware monthly for worn and or broken parts.*
- *TEST electric garage door opener's safety features monthly, according to manufacturer's instructions.*
- *DO NOT hang tools or materials from horizontal tracks.*
- *DO NOT install the garage door on windy days. Garage door could fall during the installation causing severe or fatal injury.*
- *This garage door MAY NOT meet the building code wind load requirements in your area. Contact your local building official for wind load code requirements and building permit information.*
- *WARNING LABELS are important parts of the garage door(s).*
- *Place warning labels as indicated to the right, so that they are not obstructed and can be easily read.*
- *DO NOT remove, cover or paint over the labels. Users should inspect labels periodically for legibility and should order (free of charge) replacement labels from Amarr, as needed. Please call toll free 1.800.503.DOOR or email ask@amarr.com.*

NOTICE The following four warning labels should be present on or around garage door assemblies:

1. Spring Warning Label - attached to the spring assembly;
2. General Warning Label - attached to the back of the garage door panel;
3. Warning Label for Garage Door Opener (provided separately with opener) - attached to the wall in the vicinity of the wall control button, and;
4. Bottom Bracket Tension Warning Label - attached above the garage door's bottom brackets.

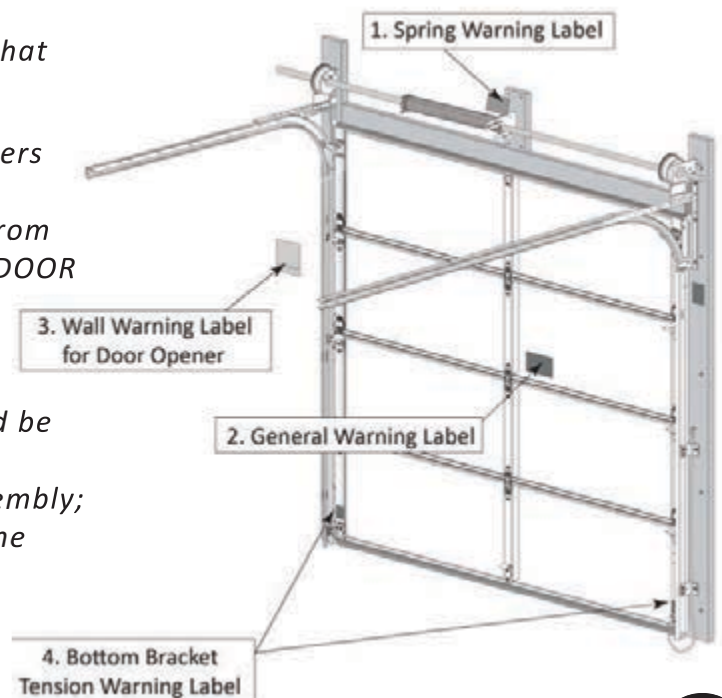



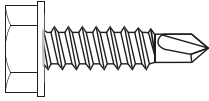
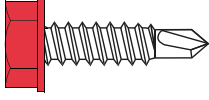
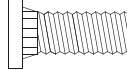
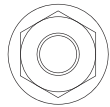
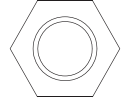
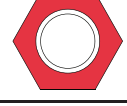
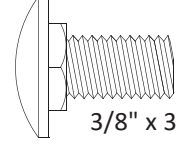
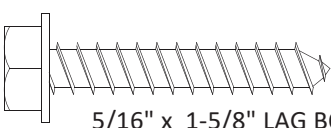
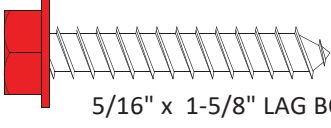
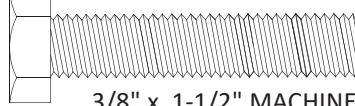









Minimum Hardware Required







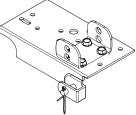

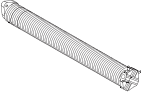

Fasteners (Actual Size) Minimum Quantity Required	4 Section Garage Door					5 Section Garage Door					6 Section Garage Door				
	Center Stiles	1	2	3	4	5	1	2	3	4	5	1	2	3	4
 1/4" x 1" SCREWS # Fastners	52	64	116	184	204	64	80	146	232	258	76	96	176	280	312
 1/4" x 1" TEK SCREWS (RED)	6					6					6				
 1/4" x 5/8" SLOTTED TRACK SPLICE BOLTS	4					12					14				
 1/4" x 20 SERR. WASHER HEAD NUTS	4					12					14				
 3/8" - 16 HEX NUT	8					8					8				
 3/8" - 16 HEX NUT (RED)	4					4					4				
 3/8" x 3/4" LOW SHOULDER CARRIAGE BOLTS	8					8					8				
 5/16" x 1-5/8" LAG BOLTS	10 (WOOD MOUNT ONLY)					14 (WOOD MOUNT ONLY)					16 (WOOD MOUNT ONLY)				
 5/16" x 1-5/8" LAG BOLTS (RED)	8 (WOOD MOUNT ONLY)					8 (WOOD MOUNT ONLY)					8 (WOOD MOUNT ONLY)				
 3/8" x 1-1/2" MACHINE BOLTS	4					4					4				

NOTICE

For wind load certified doors, a wind load specific drawing will accompany your garage door, showing where the extra parts are located.

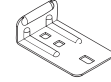
Standard Lift Applications Minimum Hardware Required

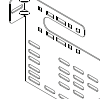
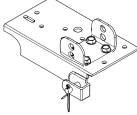
6' to 12' Tall	4 Section Garage Doors	5 Section Garage Doors	6 Section Garage Doors
 Center Hinge	3	4	5
 Roller Carriers (numbered)	6	8	10
 Jamb Brackets (bracket mount only)	6	8	10
 Torsion Cables	One Pair	One Pair	One Pair
 Rollers (yours may appear different)	10	12	14
 Cable Drums	One Left & One Right	One Left & One Right	One Left & One Right
 Top Fixture	2	2	2
 Step Plate Lift Handle	Minimum 2	Minimum 2	Minimum 2
 Center Bearing Plate	1	1	1
 End Bearing Plate	One Left & One Right	One Left & One Right	One Left & One Right
 Bottom Fixture (assembled)	One Left & One Right	One Left & One Right	One Left & One Right
 End Stile Slide Lock	Minimum 1	Minimum 1	Minimum 1
 Torsion Spring	Minimum 1	Minimum 1	Minimum 1

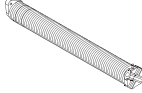
12'-3" to 16' Tall	7 Section Garage Doors	8 Section Garage Doors
 Center Hinge	6	7
 Roller Carriers (numbered)	12	14
 Jamb Brackets (bracket mount only)	12	14
 Torsion Cables	One Pair	One Pair
 Rollers (yours may appear different)	16	18
 Cable Drums	One Left & One Right	One Left & One Right
 Top Fixture	2	2
 Step Plate Lift Handle	2	2
 Center Bearing Plate	1	1
 End Bearing Plate	One Left & One Right	One Left & One Right
 Bottom Fixture (assembled)	One Left & One Right	One Left & One Right
 End Stile Slide Lock	1	1
 Torsion Spring	1	1

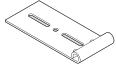
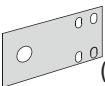
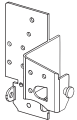
	* Low Headroom Top Fixture	2
	* End Bearing Plate (lowhead rear mount only)	2
	* Low Headroom Outside Hook-Up Bottom Fixture	One Left & One Right

*Low Headroom Applications Only

NOTICE

Your door kit may contain more parts than shown here. These are the minimum parts required for most single car garage door installations.

Required Parts

5

Jamb and Spring Pad Detail

⚠ WARNING

WARNING - Strike Hazard

The jamb and spring pad **MUST** be securely anchored to the wall. Failure to secure the jamb or spring pad could result in death or serious bodily injury.

DO NOT use nails to secure the track or spring pad.

*Consult Dasma TDS-161 (www.dasma.com) for details specific application.

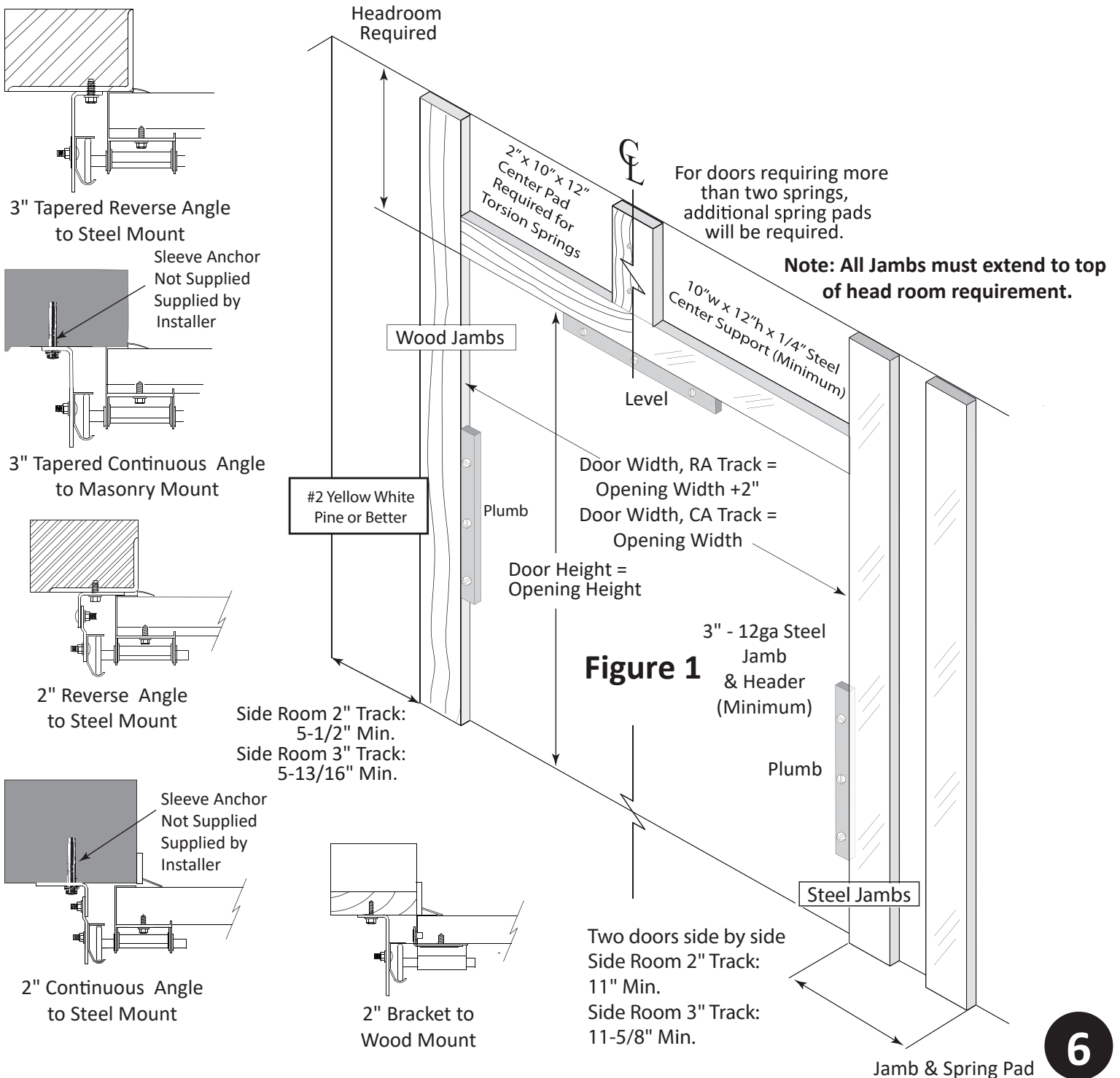

Jamb and Spring Pad Detail

Table 1 - Headroom Chart

TORSION SPRING HEADROOM REQUIREMENTS FOR STANDARD LIFT DOORS					
TRACK RADIUS	DOOR HEIGHT	END BEARING PLATE	DRUM	HEADROOM (2" TRACK)	HEADROOM (3" TRACK)
15"	UP TO 8' TALL	3-3/8" EBP	D400-96	15"	16-3/8"
	8'3" - 12' TALL	3-3/8" EBP	D400-144	15"	16-3/8"
	12'3" - 18' TALL	UNIVERSAL EBP	D525-216	15-1/2"	16-7/8"
	18'3" - 20' TALL	UNIVERSAL EBP	D800-384	18-3/4"	20"

FOR LOW HEADROOM TORSION TO THE FRONT DOORS				
DOOR HEIGHT	END BEARING PLATE	DRUM	HEADROOM (2" TRACK)	HEADROOM (3" TRACK)
UP TO 8' TALL	3-3/8" EBP	D400-96	11-3/16"	12-1/8"
8'3" - 12' TALL	3-3/8" EBP	D400-144	11-3/16"	12-1/8"
12'3" - 16' TALL	UNIVERSAL EBP	D525-216	12-3/16"	13-1/8"
16'3" - 18' TALL	UNIVERSAL EBP	D525-216	12-3/16"	13-1/8"
18'3" - 20' TALL	UNIVERSAL EBP	D800-384	15-1/16"	16"

FOR LOW HEADROOM TORSION TO THE REAR DOORS				
DOOR HEIGHT	END BEARING PLATE	DRUM	HEADROOM (2" TRACK)	HEADROOM (3" TRACK)
UP TO 8' TALL	3-3/8" EBP	D400-96	6-1/2"	7-5/8"
8'3" - 12' TALL	3-3/8" EBP	D400-144	6-1/2"	7-5/8"
12'3" - 16' TALL	UNIVERSAL EBP	D525-216	6-1/2"	7-5/8"
16'3" - 18' TALL	UNIVERSAL EBP	D525-216	6-1/2"	7-5/8"
18'3" - 20' TALL	UNIVERSAL EBP	D800-384	7-5/16"	8-1/2"

Note: An additional 4" of headroom is required if trolley operator is installed.

Note: Low headroom torsion to the rear is not available.

Installing Hardware

Step 1: Framing the Opening

The jambs must be plumb and the header level for a square opening. All jamb fasteners should be flush with the jambs and securely anchored to the wall. Refer to Figure 1, Page 6.

Step 2: Perimeter Seal Installation

For wood jambs only, refer to page 30 for details. Perimeter Seal is to be purchased separately. It is not supplied with your door and is not required.

Step 3: Bottom Section Assembly

The bottom section has a rubber weather seal on the bottom. If not, slide the Rubber Astragal into the Retainer.

Step 4: Bottom Bracket Installation - right side

Place the bottom section face down on a sturdy pair of padded saw horses (Figure 2, page 9). Insert the Cable Pin into the round hole in the Bottom Bracket, from the inside. Then insert the looped end of the Lift Cable onto the Cable Pin. Push the Cable Pin through the round hole from the inside (Figure 2a). With the Lift Cable securely installed, slide the Cotter Pin (Figure 2a) through the hole in the Cable Pin, then bend out one leg of the Cotter Pin. Slide the right Bottom Bracket to the bottom of the right end stile (Figure 2a). Fasten the flat base of the Bottom Bracket with (3) 1/4-20 x 1" RED TEK Screws (Figure 2a). Fasten the Roller Bracket with (4) 1/4-20 x 1" TEK Screws. Insert the Long Stem Roller into the Roller Bracket (Figure 2a).

Repeat Step 4 for the left side Bottom Bracket

Note A: Some Bottom Brackets may require cutting a slot into handles, and locks. Use a 3/32" drill bit to start pilot holes for fasteners where pre-drilled holes are not provided.

Step 5: Lift Handle Installation

(Models 3502, 3552, AX 3592, VI1000, HO1000, 2432, 2731, 2002, 2012, 2022, 2402, 2412, 2422, 2502, 2512, 2732, 3040, 3582)

Install the inside and outside Lift Handles using (4) 1/4-20 x 1" TEK screws as shown (Figure 2b).

Step 5a: Lift Handle Installation

(Models 2042, 2442, 2742, 2741, 2743, 2747)
Install the inside and outside Lift Handles using (2) 1/4 -20 Carriage Bolts and (2) 1/4 - 20 Nuts (Figure 2c).

Note B: If additional reinforcement (struts) are supplied with your door, refer to page 18 for proper number, size and location.

Step 6: Roller Hinge Installation - right side

Roller Hinges have a number stamped on them for the end stiles with (2) 1/4-20 x 1" TEK Screws, with the center line of the hinge aligned along the section break.

2" Track: Start with a #1 Roller Hinge on the bottom section. Insert rollers as shown (Figures 2d & Table 3, page 12).

3" Track: Start with a #3 Roller Hinge on the bottom section. Insert rollers as shown (Figures 2d & Table 3, page 12).

Note C: Doors Requiring Double End Stiles (DES) Doors wider than 16'-2" require DES (Figure 2f). Additional Roller Hinges must be installed to the inside of the outside Roller Hinges (repeat Step 6, page 10, with the Roller Hinges mounted to the inside).

Repeat Step 6 for left side

Note D: #1 Roller Hinges are always used as Center Hinges. All other Roller Hinges must not be used as Center Hinges. They are all marked with their identifying numbers.

3552 HD / VISTA SECTION ARRANGEMENT CHART

	BTM	INT	TOP	BTM	INT	TOP	BTM	INT	TOP
Door	18"	18"	18"	21"	21"	21"	24"	24"	24"
6'0"							1	1	1
6'3"		2	1	1					
6'6"		2		1		1			
6'9"		1		1	1	1			
7'0"				1	2	1			
7'3"					2	1	1		
7'6"					2		1		1
7'9"					1		1	1	1
8'0"							1	2	1
8'3"		2		1	1	1			
8'6"			1	1	2	1			
8'9"				1	3	1			
9'0"					3	1	1		
9'3"					3		1		1
9'6"					2		1	1	1
9'9"					1		1	2	1
10'0"							1	3	1
10'3"		1		1	3				1

For heights greater than 10'3", refer to Table 2

⚠ WARNING

- RED fasteners must be used where required.
- These fasteners hold parts which are under extreme tension.
- RED fasteners are not to be loosened or removed.

Installing Hardware

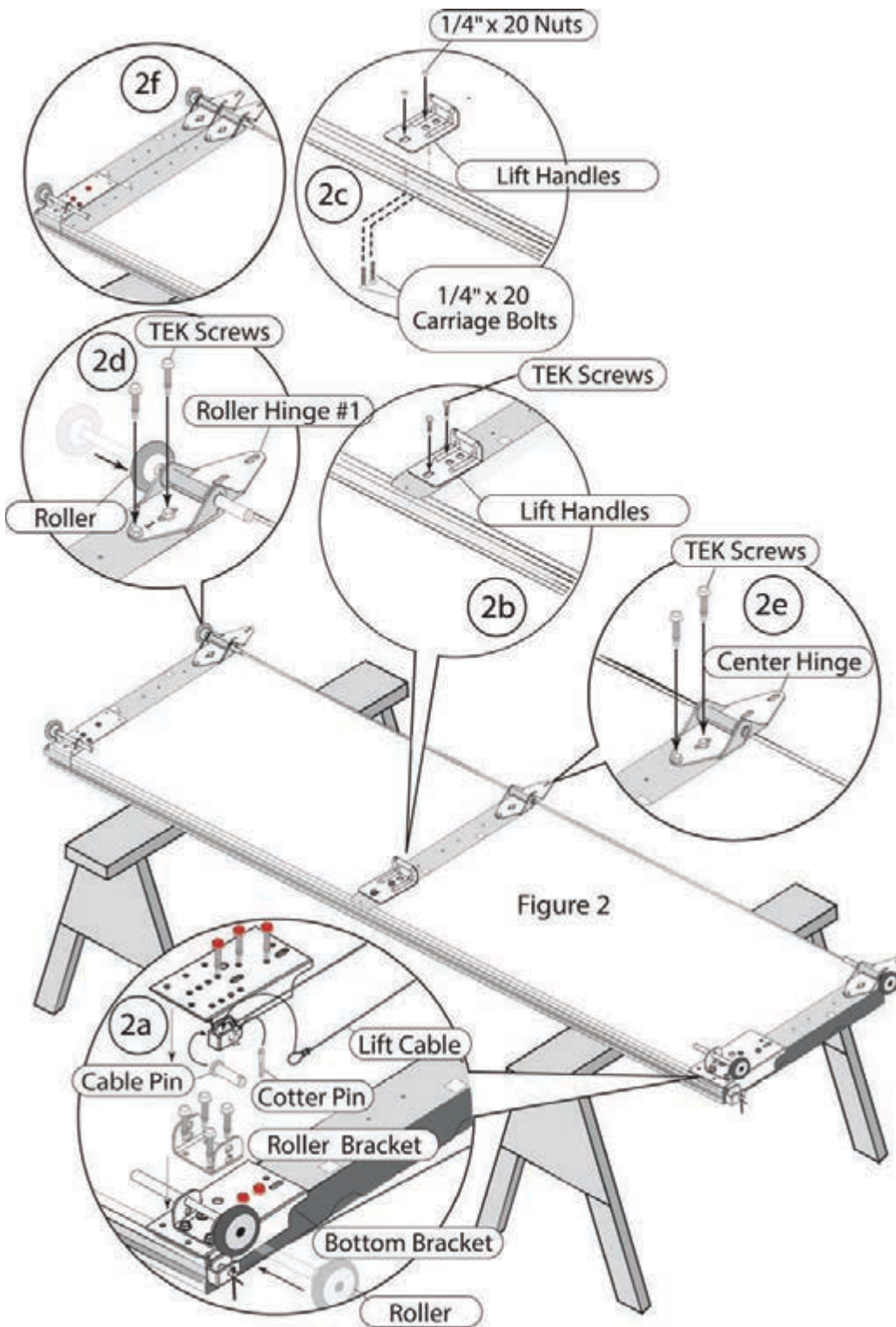

Figure 2

Amarr 3040 Bottom Bracket w/Spacer Install Requirement

Attach (2) Roller Spacers to each Long Stem Roller prior to installing the bottom brackets.

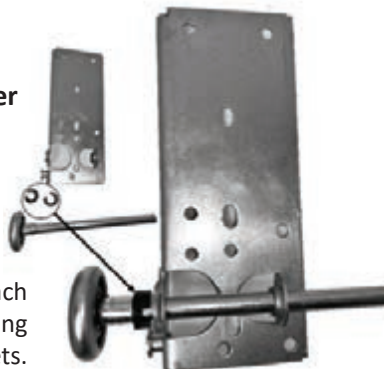

Table 2 - DOOR HEIGHT CONFIGURATION

Door Height	21" Sections	24" Sections
7'0"	4	
7'3"	3	1
7'6"	2	2
7'9"	1	3
8'0"		4
8'3"	Not Available	
8'6"	Not Available	
8'9"	5	
9'0"	4	1
9'3"	3	2
9'6"	2	3
9'9"	1	4
10'0"		5
10'3"	Not Available	
10'6"	6	
10'9"	5	1
11'0"	4	2
11'3"	3	3
11'6"	2	4
11'9"	1	5
12'0"		6
12'3"	7	
12'6"	6	1
12'9"	5	2
13'0"	4	3
13'3"	3	4
13'6"	2	5
13'9"	1	6
14'0"		7
14'3"	7	1
14'6"	6	2
14'9"	5	3
15'0"	4	4
15'3"	3	5
15'6"	2	6
15'9"	1	7
16'0"		8

For heights above 16'0"
Contact Amarr Engineering

Installing Sections

Step 7: Center Hinge Installation

Position the Center Hinge as shown (Figure 2e). All Center Hinges are attached with (2) 1/4-20 x 1" TEK Screws in the lower section.

Note A: Shown is a Single Center Hinge door, your application may have more Center Stiles and Center Hinges.

Step 8: Stacking the Bottom Section in the Opening

Bring the Bottom Section (with hardware installed) to the opening. Place against the Jamb and center from side to side (Figure 3). Place a level on the top of the section (Figure 3a). If necessary, use a shim under the low side to make the section level (Figure 3b).

Note B: If you raise one side of the bottom section to level it, you must raise the track on that side the same amount for the door to operate properly (Figure 3b).

Note C: Temporarily loop the lift cables and hang them over the rollers (Figure 3c). This will keep them out of the way until ready for use.

Note D: Fold down the upper leaves of the Roller Hinges and Center Hinges before proceeding to the next step.

Step 9: Installing Angle Mount Track Assembly

Option A: Lift the Left Side Vertical Track Assembly up and down onto the Left Side Roller and against the Jamb (Figure 4a).

Option B: Bring the Left Side Vertical Track Assembly over to the jamb. Rotate the track assembly into place around the rollers (Figure 4b).

Note E: If required, optional Reverse Angle Jamb Seal may be installed by sliding the seal onto the leg-in angle (Figure 4f).

Note F: Maintain a 1/2" space between the door edge and the vertical track assembly (Figure 4b). Using a level against the Track Assembly (Figure 4e), be sure the assembly is plumb. Pre-drill holes through the slots in the angle (using a 3/16" drill bit), to help start the screws into the jamb (Figure 4c). With the track assembly properly aligned and plumb, securely attach the Track Assembly to the jamb using:
(1) 5/16" x 1" IHWH TEK Screws (Mount to Steel)
(1) 5/16" x 1-5/8" Lag Bolts (Mount to Wood),
in every slot in the Vertical Angle as shown (Figure 4d).

Note G: Your application may require more or fewer Screws to fasten to the jamb, depending on the height of the door.

Note H: Vertical tracks must be level with each other for the door to function properly. If not level (one side has been shimmed), raise the vertical track on that side equal to the shim under the bottom section (Figure 3b). Vertical tracks must be plumb as well.

Repeat Step 9 for Right Side Vertical Track Assembly (Figure 4e)

TRACK INSTALLATION TO STEEL JAMBS, IS SHOWN WITH THE VERTICAL ANGLE

ALTERNATE APPLICATIONS TO WOOD OR CONCRETE WILL REQUIRE ANGLE TO BE LEG OUT, TO AVOID CRACKING OR SPLITTING.

NOTICE

Door Shown MAY NOT meet the building code wind load requirements in your area. Contact your local building official for wind load code requirements and building permit information.

WIND LOAD TRACK MAY REQUIRE ADDITIONAL REINFORCEMENT: REFER TO THE WIND LOAD DRAWINGS SUPPLIED WITH YOUR DOOR OR CONTACT YOUR AMARR REPRESENTATIVE FOR DETAILS

Installing Sections

Track raised the same amount as the section when a shim is used.

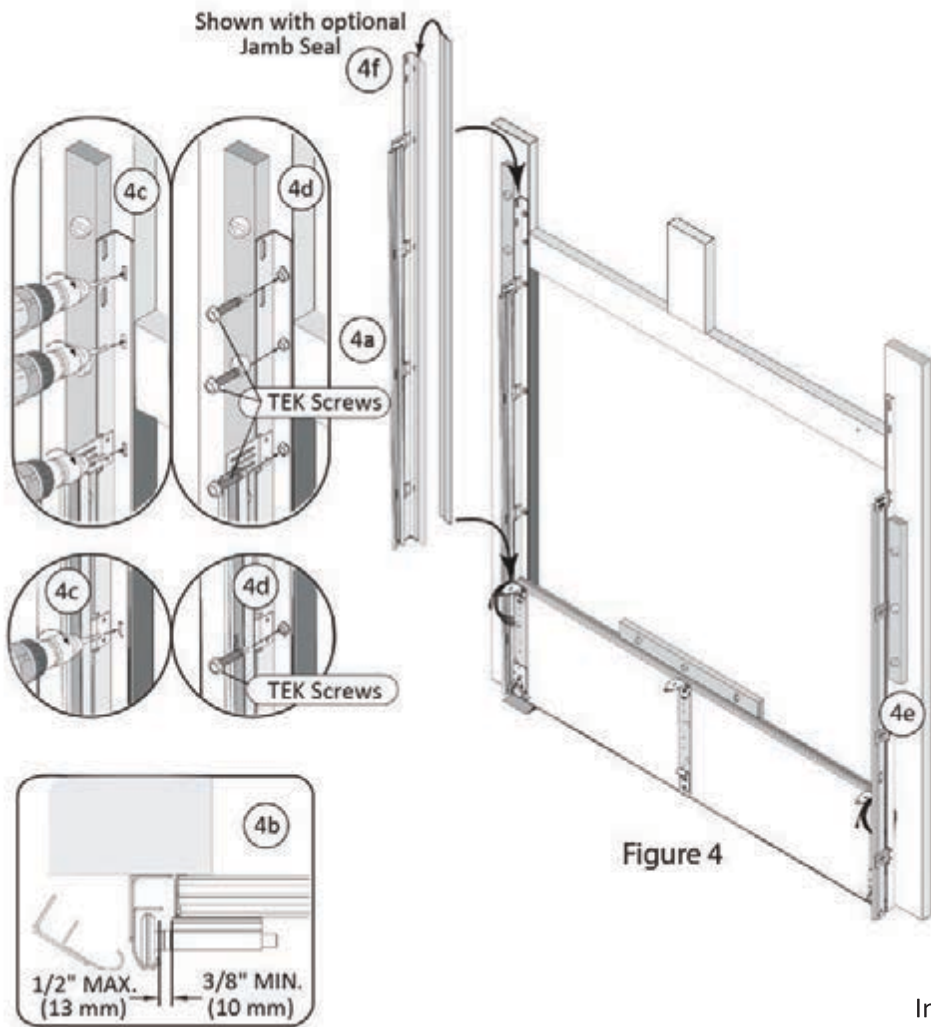
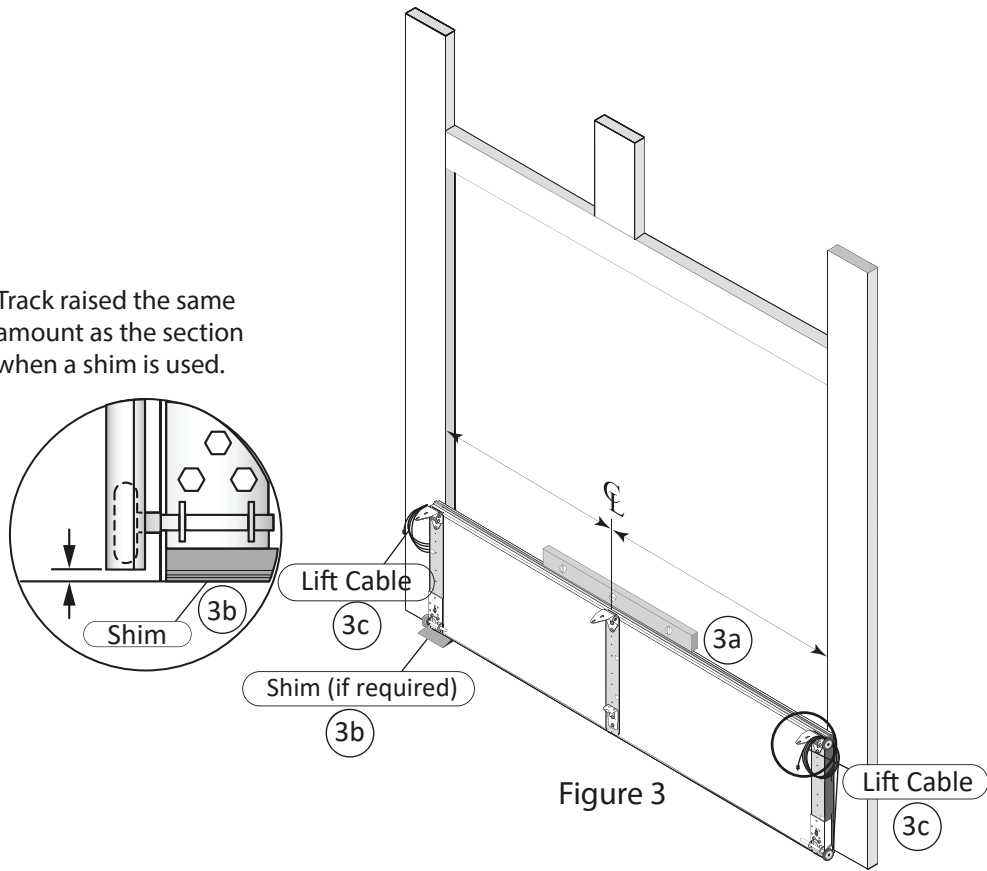

Installing Intermediate Sections

Step 10: Installing Intermediate Section Hardware

Note A: “Intermediate” refers to sections above the bottom section and below the top section. Intermediate sections are interchangeable.

Place the second section face down on the padded saw horses. Install the left side Roller Hinge and Roller as shown on page 8, Step 6 (Figure 2d). Do not install the right side Roller Hinge at this time.

Install the Center Hinge(s) as show on page 8 (Figure 2e), page 10, Step 7.

Note B: Install locks if required or provided. Refer to page 29 for slide lock installation or instructions may be provided with your locks.

Step 11: Installing Intermediate Sections in the Opening

Carefully lift the Intermediate Section, with Roller, Roller Hinges, Center Hinge(s) and Strut(s) (if required) to the height of the Bottom Section (or next Intermediate section). Bring the door in at a 45° angle and insert the left side roller into the left side vertical track (Figure 5a).

Carefully rotate the Intermediate Section around until it is parallel and lines up with the section below. Slowly lower the section down onto the bottom section that you stacked earlier (Figure 5b).

CAUTION

Pinch and Strike Hazard. Secure the end hinge with appropriate universal screws (see Figure 6b). Failure to properly secure the hinge could result in minor or moderate bodily injury. Wear work gloves and safety glasses.

After the Intermediate Section is seated, install the right side Roller Hinge with the Roller (inserting the Roller into the track) using (2) 1/4-20 x 1" TEK Screws (Figure 6a).

Note C: Lay down the upper leaves of the Roller Hinges and Center Hinges before proceeding to the next step (Figures 6a & 6b).

Repeat Steps 10 & 11 as required for Intermediate Sections. Refer to Table 3 for correct Roller Hinge progression.

Continue to:

Page 31 for Low Head Room Torsion to the Front

Page 33 for Low Head Room Torsion to the Rear

Page 35 for High Lift

Page 37 for Vertical Lift

Page 40 for Follow the Roof Pitch

Go to Step 12 when all Intermediate Sections are installed and track installation is completed. Do not install the Top Section at this time.

Table 3 - ROLLER HINGE PROGRESSION		
Section #	Roller Hinge # 2" Track	Roller Hinge # 3" Track
#8	8	10
#7	7	9
#6	6	8
#5	5	7
#4	4	6
#3	3	5
#2	2	4
Bottom #1	1	3

For heights above 16'0"
Contact Amarr Engineering

Installing Intermediate Sections

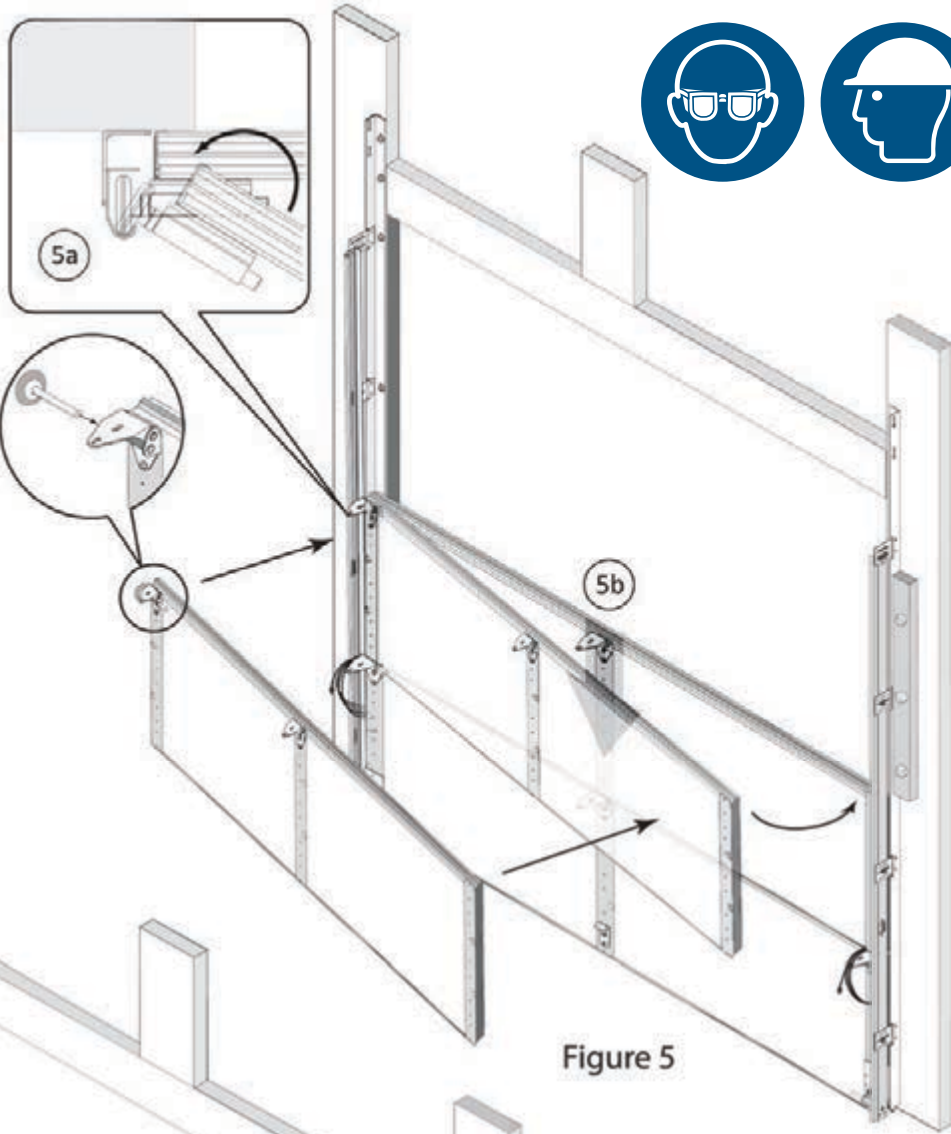

Figure 5

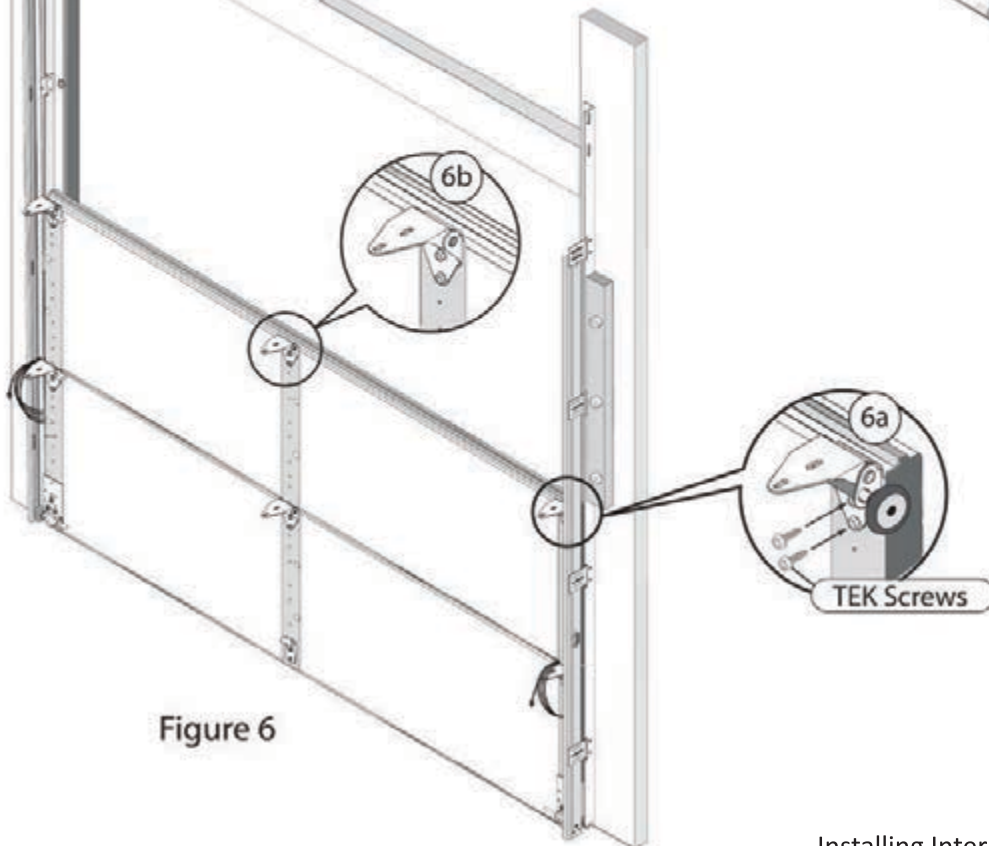

Figure 6

Installing Horizontal Track

Step 12: Horizontal Track to Vertical Track Attachment

(left side assembly shown)

Attach the radius (curved) end of the Horizontal Track Assembly to the Vertical Track with (2) 1/4" x 5/8" Track Splice Bolts and (2) 1/4"-20 Hex Nuts (Figure 7a).

Temporarily support the back end of the track.

Adjustment to the track position may need to be made later (to maintain the proper spacing) after the springs are installed and the door is opened and closed.

Note A: 1/4" x 20 Hex Nuts always go on the outside of the assembly (away from the door).

Step 13: Horizontal Angle to Vertical Angle Installation

Attach the end of the Horizontal Angle to the Vertical Angle with (1) 3/8" x 3/4" Low Shoulder Carriage Bolt and (1) 3/8"-16 Hex Nut (Figure 7b).

Note B: 3/8"-16 Hex Nuts always go on the outside of the assembly (away from the door).

Step 14: Back Hanger Installation

⚠WARNING (see page 27)

BACK HANGERS MUST BE ABLE TO SUPPORT THE WEIGHT OF THE TRACK AND THE DOOR.

Install metal Angle Hangers (Figure 7c & 7d). Angle is purchased separately, minimum 14 ga. Hangers need to be level and plumb. Angle must fasten to studs (Page 27).

Note C: Doors with 3" track and/or greater than 10' tall require additional Intermediate Hangers (Figure 7e).

Note D: Repeat Steps 12-14 for Right Side Horizontal Assembly.

Important: Horizontal Track must be spaced 3/8" - 1/2" from the sections to prevent the sections from falling out of the track.

Step 15: Inspecting the Track Installation

Using a tape measure and level, make sure the track is level and square with the opening (Figure 7). Make sure that the distance between the track and the door is equal at the bottom of the Vertical Track, at the radius of the horizontal, and at the back of the Horizontal Track.

Installing Horizontal Track



- Intermediate Hanger required on track and/or doors 11'-16' tall.
- Two Intermediate Hangers required at 16'- 18' tall.
- Over 18' tall, no more than 72" between hangers.

⚠WARNING **Overhead Crush Hazard**
 Long end of the threaded bolt must be inside of the track to act as a door stop.

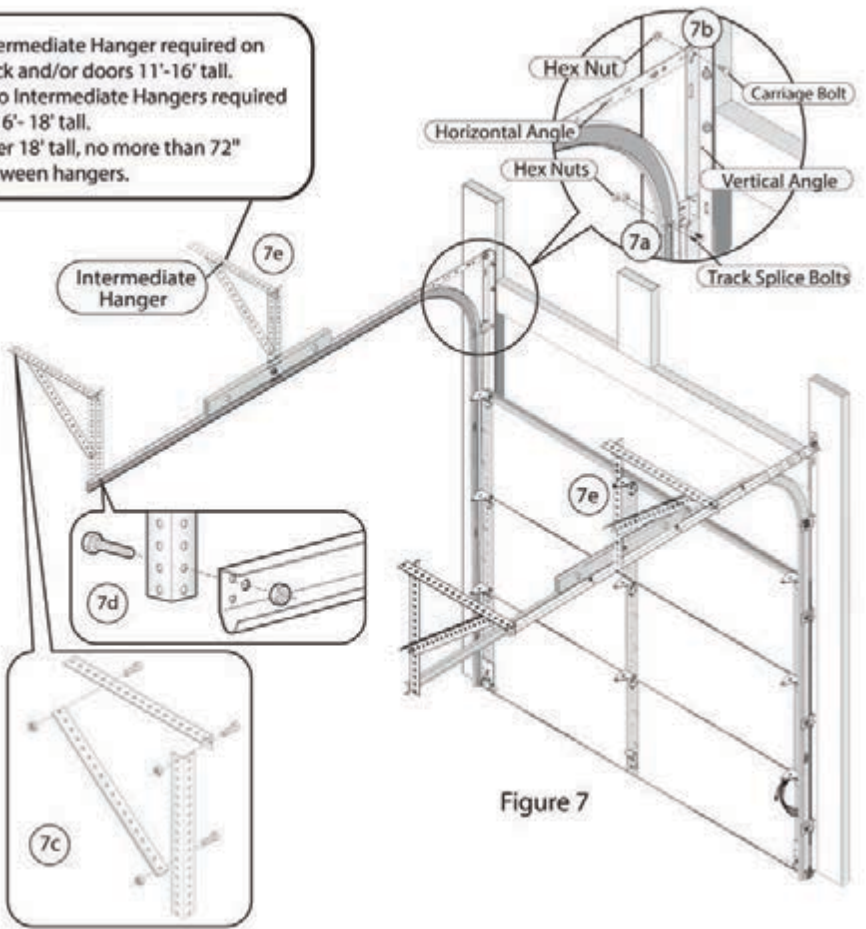

Figure 7

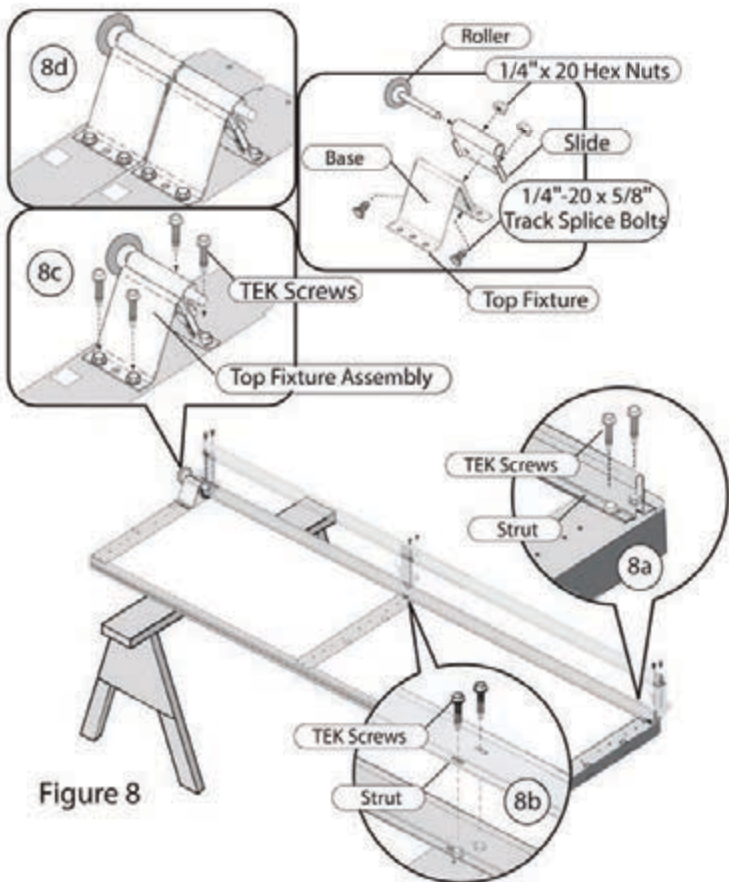

Figure 8

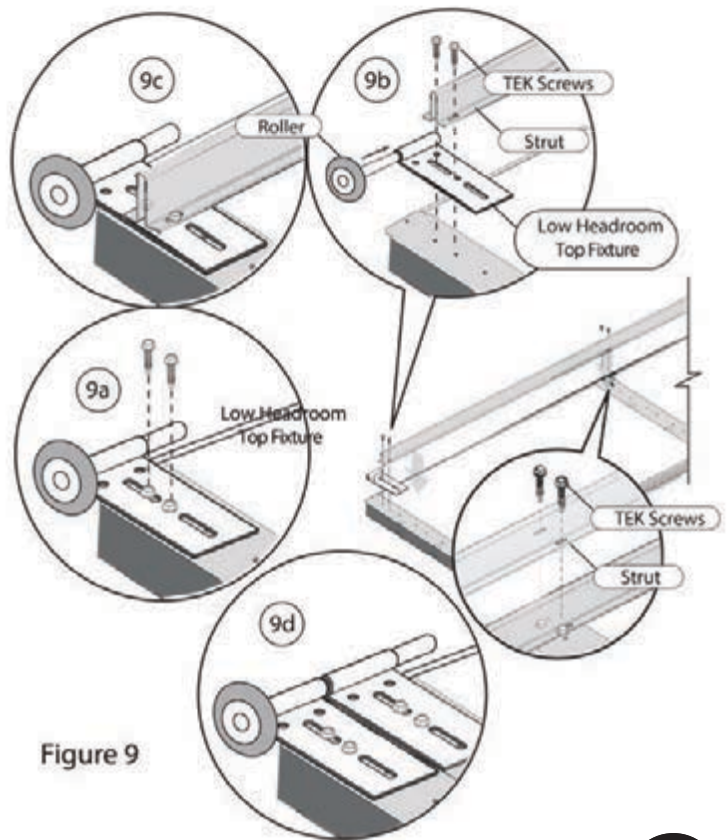

Figure 9

Installing Top Section

Step 16: Installing Top Section Hardware

Place the top section face down on your padded saw horses.

Note A: If struts are not supplied or required skip to Step 20.

Note B: Due to lack of available head room (refer to page 7, Table 1), you may require a Low Headroom application. If this is the case, skip Step 20 and go to Step 21.

Step 17: Strut Installation

If Struts are required, location is shown on page 15. Install using (2) 1/4-20 x 1" TEK Screws into each Center and End Stile (Figures 8 & 9 for low headroom).

Step 18: Top Fixture Installation

(Standard Lift, High Lift, or Vertical Lift)
Align the Top Fixture Assembly, with holes on the left side End Stile, near the top. Secure the fixture to the End Stile with (4) 1/4-20 x 1" TEK Screws (Figure 8c). Insert the rollers as shown (Figure 8c). Leave the slide loose for later adjustment.

Note C: For doors requiring Double End Stiles (DES), refer to Figure 8d, or Figure 9d (page 15, Low Headroom assemblies only).

Note D: Low Head Room Top Fixtures may require additional adjustment after the Top Section is placed in opening.

Step 20: Stacking the Top Section in the Opening

Carefully lift the Top Section, with the Roller, Top Fixture, and Struts (if required) to the height of the last intermediate section. Bring the door in at a 45° angle and insert the left side roller into the left side track (Figure 10a). Carefully rotate the Top Section around until it is parallel and lines up with the section below. Slowly lower the section down onto the section below (Figure 10b).

Step 21: Installing the Right Side Top Fixture Assembly

Align the Right Top Fixture Assembly, with holes on the Right Side End Stile.

Note E: The Right Side Top Fixture must be attached at the same (Figure 11a). Insert the rollers as shown (Figure 11a). Leave the slide loose for later adjustment.

Step 22: Center Hinge Installation

Once the Top Section is secured, push up the upper leave(s) of the Center Hinge(s) and attach to the upper section with (2) 1/4-20 x 1" TEK Screws (Figure 11b). Do this for all Center Hinges.

Step 23: End Hinge Installation

Push up the upper leave(s) of the End Hinge(s) and attach to the upper section with (2) 1/4-20 x 1" TEK Screws (Figure 11c). Do this for all End Hinges.

Step 24: Adjusting the Top Fixture

With the door in the closed position, tighten the slide on both Top Fixtures by pushing the top section tight against the opening and lightly pulling the top slide toward the inside of the garage (Figure 11d). Tighten the Hex Nuts.

Step 25: Pull Rope Installation (no Electric Opener only)

If an electric opener is not used, attach one end of the pull rope to the Bottom Bracket and the other end to the second Track Clip. To prevent accidents, DO NOT INSTALL PULL ROPE IF ELECTRIC OPENER IS USED.

Go to page 23 for Torsion Spring Unit Installation Instructions.

After springs are installed, proceed to Step 26.

Step 26: Affix Safety Stickers to Door

Affix supplied Safety Stickers as shown (Figure 11e).

Step 27: Final Check

A. Make sure there is a 1/2" - 3/8" clearance between the door and the track along the entire horizontal and vertical track assemblies. Adjust as necessary.

B. Make sure the door is square with the opening.

C. If the door does not operate easily, make sure that the door to track spacing is correct and that the door is not binding.

D. If required, go to page 29 for Slide Lock Installation Instructions.

Installing Top Section

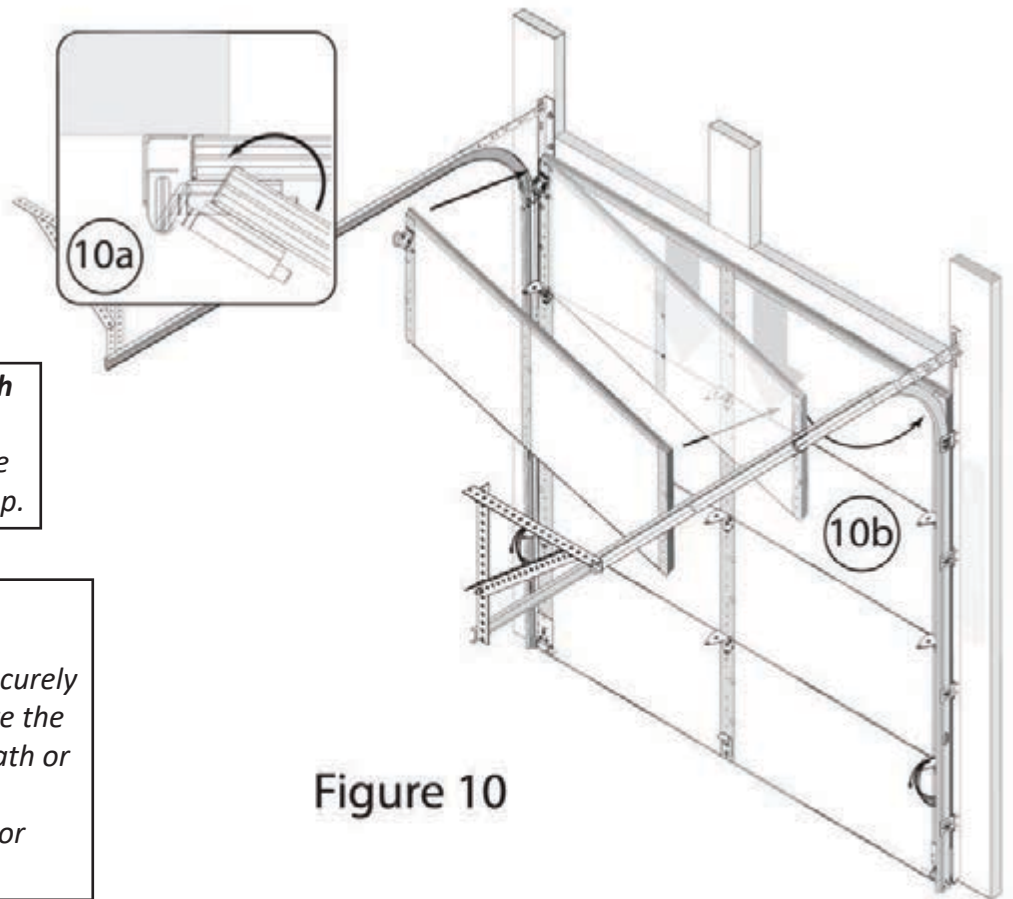

Figure 10

⚠WARNING

Overhead Crush Hazard

Long end of the threaded bolt must be inside of the track to act as a door stop.

⚠WARNING

Strike Hazard

The track and spring pad **MUST** be securely anchored to the wall. Failure to secure the track or spring pad could result in death or serious bodily injury.

DO NOT use nails to secure the track or spring pad. See Figure 1, page 6.

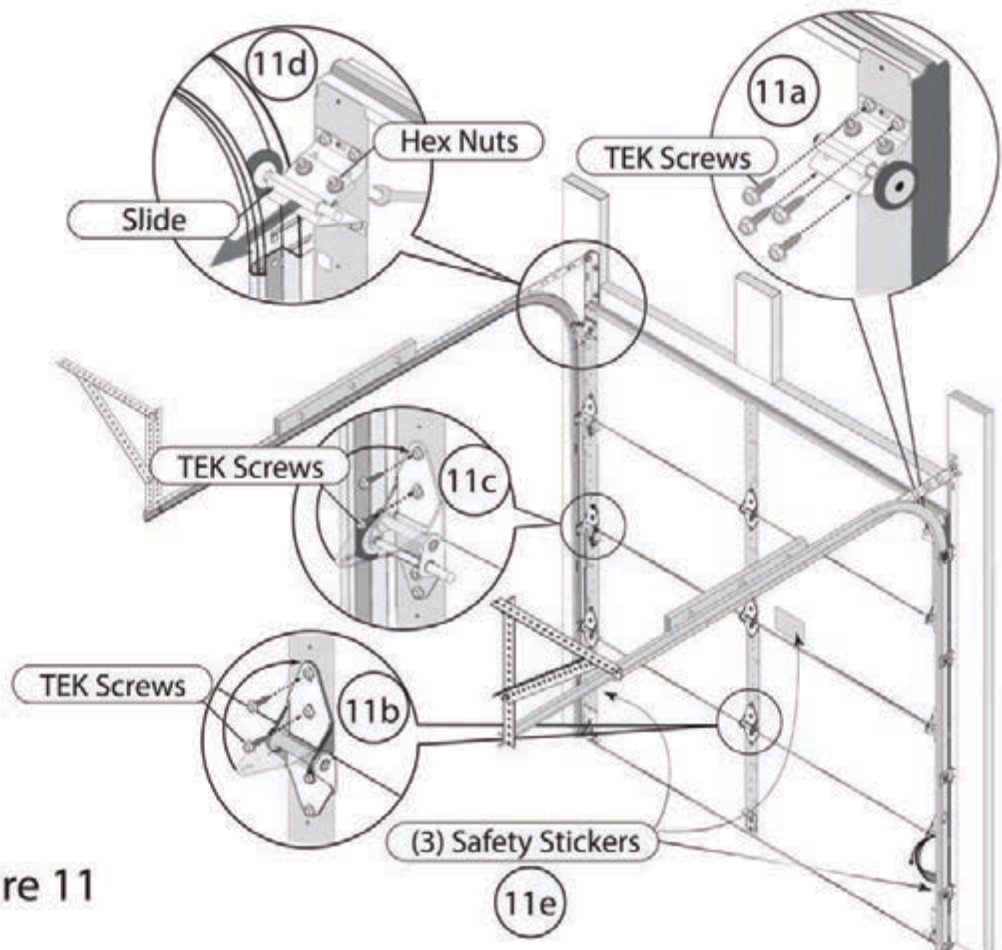

Figure 11

Strut Installation & Schedule

Step 1 of 3: Number of Struts & Strut Size

Model	Door Width	Door Height	Struts Required
Amarr 2002, 2012, 2022, 2402, 2412, 2422 2502, 2512, 2522, 3502 2" Open Back* Note: Model 3502 is only available up to 12'2" x 12'0"	8'2" - 14'2"	7' - 16'	0 Struts*
	14'4" - 20'2"	7' - 16'	(1) 2" 20 ga Strut per Section
	20'4" - 24'2"	7' - 16'	(1) 3" 20 ga Strut per Section
Amarr 2731 1-3/8" EPS	8'2" - 14'2"	7' - 16'	0 Struts*
	14'4" - 16'2"	7' - 10"	(3) 2" 20 ga Struts
	14'4" - 16'2"	11' & 12'	(4) 2' 20 ga Struts
Amarr 2743 3" Polyurethane Amarr 2442 & 2742 2" Polyurethane Amarr 2747 1-5/8" Polyurethane	8'2" - 12'2"	7' - 16'	0 Struts*
	12'4" - 16'0"	7' - 16'	(3) 2" 20 ga Struts
	16'2" - 18'2"	7' - 16'	(1) 2" 20 ga Strut per Section
Amarr 2432 2" EPS - 24 ga Amarr 2732 2" EPS - 27 ga †22'2" and wider use 3" 18 ga Struts	8'2" - 12'2"	7' - 16'	0 Struts*
	12'4" - 14'2"	7' - 16'	(3) 2" 20 ga Struts
	14'4" - 18'0"	7' - 10'	(3) 2" 20 ga Struts
	14'4" - 18'0"	11' - 14'	(4) 2" 20 ga Struts
	14'4" - 18'0"	15' & 16'	(5) 2" 20 ga Struts
	18'2" - 20'0"	7' & 8'	(3) 2" 20 ga Struts
	18'2" - 20'0"	9' - 16'	(1) 2" 20 ga Strut per Section
	20'2" - 24'2"	7' - 16'	(1) 3" 20 ga Strut per Section†
Amarr 2741 1-3/8" Polyurethane Amarr 3040 1" Polyurethane	8'2" - 14'2"	7' - 14'	0 Struts*
	14'4" - 16'2"	7' - 10'	(3) 2" 20 ga Struts
	14'4" - 16'2"	11' - 12'	(4) 2" 20 ga Struts
	14'4" - 16'2"	13' - 14'	(1) 2" 20 ga Strut per Section
	16'4" - 18'2"	7' & 8'	
Amarr 2042 2" Polyurethane	8'2" - 15'0"	7' - 16'	0 Struts*
	16'0" - 18'2"	7' - 16'	(1) 2" 20 ga Strut per Section
	18'4" - 28'2"	7' - 16'	(1) 3" 20 ga Strut per Section

*Minimum one (1) strut required, on the top section, for doors with *Trolley Operators*

Vista VI1000, Horizon HO1000, Amarr 3552, 3582 & AX3592 Strut Schedule on pages 44 & 45

Strut Installation & Schedule

Step 2 of 3: Strut Location

Indicates the placement of struts based on the number of struts required and the number of sections.

Door Height	# Sections
7'0" - 8'0"	4
8'9" - 10'0"	5
10'6" - 12'0"	6
12'3" - 14'0"	7
14'3" - 16'0"	8

5 Sections			
4 Sections		Top	1
Top	1	Int	
Int		Int	3
Int	3	Int	
Bot	2	Bot	2

Struts # Struts

8 Sections					
6 Sections		7 Sections		Top	1
Top	1	Int		Int	5
Int		Int		Int	
Int	3	Int	3	Int	3
Int	4	Int		Int	4
Int		Int	4	Int	
Bot	2	Bot	2	Bot	2

Struts # Struts # Struts

ELECTRIC OPENER ATTACHMENT

When installing a garage door opener, the following applies:

1. The garage door springs must be in good working order and the door must be balanced (should be able to raise the door half way and have the door stay in place).
2. The top section of the garage door MUST include a strut (see page 15, Figure 8 & 9 for Low Headroom).
3. Disconnect and/or remove all locks and pull ropes. Attempting to use the opener while door is locked will damage your garage door. FAILURE TO DO SO WILL VOID DOOR WARRANTY.

NOTICE This garage door MAY NOT meet the building code wind load requirements in your area. Contact your local building official for wind load code requirements and building permit information.

Many Amarr garage doors have engineering drawings to meet wind load requirements. Garage doors must be assembled precisely as shown in the drawings.

Strut Detail Example:

14'-4" x 12'-0" Amarr 2432 - (6) Sections - (3) 2" 20 ga Struts

Step 1: Number of struts - (3) 2" 20 ga.

Step 2: Strut Location

Step 3: Strut Attachment

(A) (B)	Top	1
	Int	
(C) (D)	Int	3
	Int	
	Int	
(C) (D)	Bot	2

6 Sections

Step 3 of 3: Strut Attachment

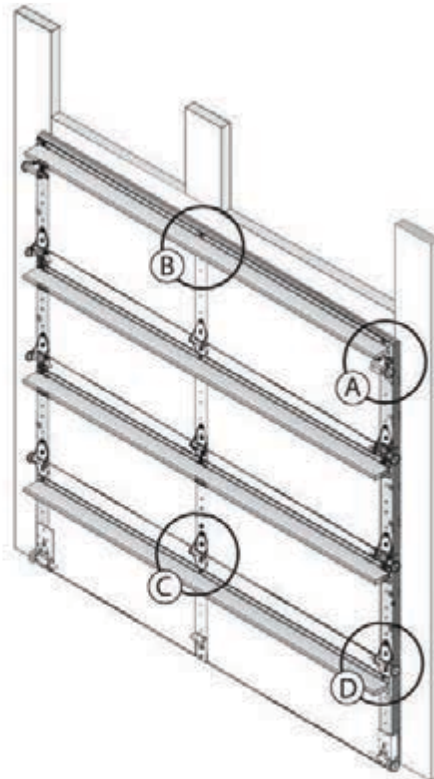
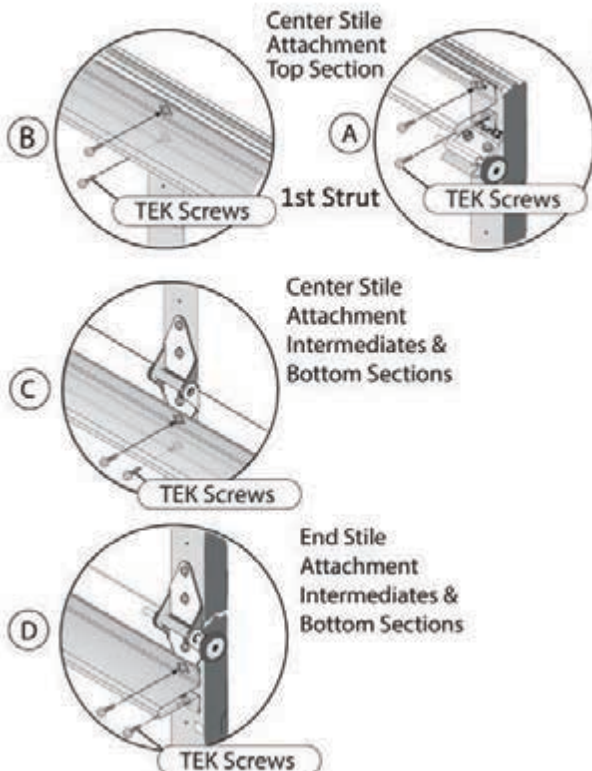

Universal End Bearing Plate (EBP) Installation Instructions

Note A: Doors may be supplied with 1, 2 or 4 Torsion Springs. Directions for installation of the Universal End Bearing Plate are the same.

Note B: Doors weighing up to 800 lbs. will require the 400 lb. Extended Bolt on Bearing (p/n 99381575). 1" Shaft only.

Note C: Doors exceeding 800 lbs. (using the Heavy Duty Cast Bolt on Bearing) require a Spacer (supplied with the bearing) to be installed between the drums and the Universal Bearing Plate (Figure 3a). The Spacer will position the drums off the side of the Universal Bearing Plate so the Carriage Bolt heads do not interfere with the Drums.

Note D: Example shown is left side, leg in, installation to steel. For installation to wood or masonry, you may reverse the Universal End Bearing Plates to install leg out.

Left Side Universal End Bearing Plate Installation

Note E: Drums can be identified for model and left or right by finding the description and L or R on the same side of the drum as the set screws (Figure 3b).

Step 1: Determine the Center Line of the Bolt on Bearing (Figure 1a) and mark or scribe. When the Bolt on Bearing is aligned correctly, the Center Line is 2" from either side. Slots should run horizontally as shown in Figure 1a.

Step 2: Align the Center Line mark with the 3 - 3/8", 4 - 3/8", 5" or 6" mark on the Universal End Bearing Plate (Figure 1b). Choose the dimension that matches the drum you are using by referencing Chart 1.

Example: The 400-144 drum would use the 3 - 3/8" mark.

Step 3: After correct alignment has been determined, fasten the Bearing to the Bearing Plate with (4) 3/8-16 x 3/4" Low Shoulder Carriage Bolts and (4) 3/8-16 Hex Nuts (Figure 1c & 1d).

Note F: 3/8"-16 Hex Nuts always go to the outside of the Universal Bearing Plate, away from the drums.

Step 4: With the leg against the jamb, fasten the completed Universal End Bearing Plate Assembly to the Horizontal Angle and Vertical Angle using (3) 3/8-16 x 3/4" Low Shoulder Carriage Bolts and (3) 3/8"-16 Hex Nuts (Figure 2a). Slots will line up with holes in the Horizontal and Vertical Angle. To determine which row of slots to fasten the Universal End Bearing Plate to, refer to Chart 2 and Figure 2b.

Example: Applications using the 800-384 drums (5" or 6" EBP dimension, Chart 1), and 15R track, you would use the lower row of slots marked 5-6 in Figure 2b, and as illustrated in Figure 2a.

Note G: For all 12" radius applications, use the row of slots identified in Figure 2b.

Step 5: Press the leg of the Universal Bearing Plate against the Jamb. Attach the Universal Bearing Plate to the jamb with (1) 1/4-20 x 1" TEK Screw (Figure 2c).

⚠ WARNING Do not attach Track, DBP or Spring components directly to sheet rock.

Note H: Universal End Bearing Plate is shown with the leg mounted facing in (leg in), but may be mounted leg out. Bearing must always be mounted to the outside, away from the drum.

Repeat Steps 1-5 for the Right Side End Bearing Plate

For Torsion Spring Installation Instructions refer to page 23.

Note: DO NOT remove warning label (hang tag) from the center bearing plate.



Universal End Bearing Plate (EBP) Installation Instructions

⚠️WARNING High Spring Tension

DO NOT remove, repair or adjust springs or anything to which garage door springs are fastened, such as wood blocks, steel brackets, cables or other like items. Failure to follow these instructions could result in death or serious bodily injury. Repairs and adjustments must be made by a trained door system technician using proper tools and instructions.

Chart 1 - Reference Figure 1b

Bolt-on Bearing Spacing	
Drums	Dimensions
400-96	3-3/8
400-144	3-3/8
525-216	3-3/8
800-384	5 - 6
<hr/>	
5250-54	4-3/8
5750-120	5 - 6
6375-164	5 - 6

Chart 2 - Reference Figure 2b

Universal Bearing Plate Spacing	
Drums	Dimensions
400-96	3-3/8 or 4-3/8
400-144	3-3/8 or 4-3/8
525-216	3-3/8 or 4-3/8
800-384	5 - 6
<hr/>	
5250-54	3-3/8 or 4-3/8
5750-120	5 - 6
6375-164	5 - 6

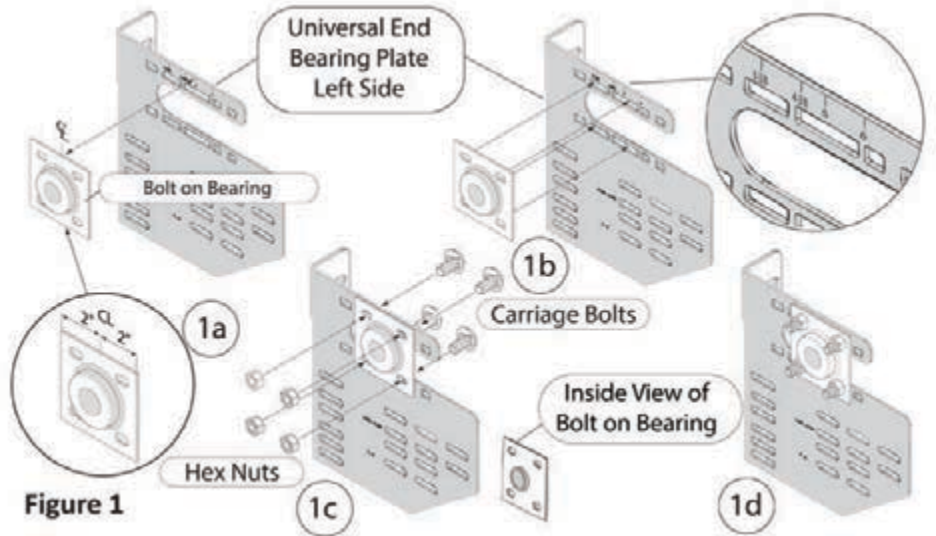

Figure 1

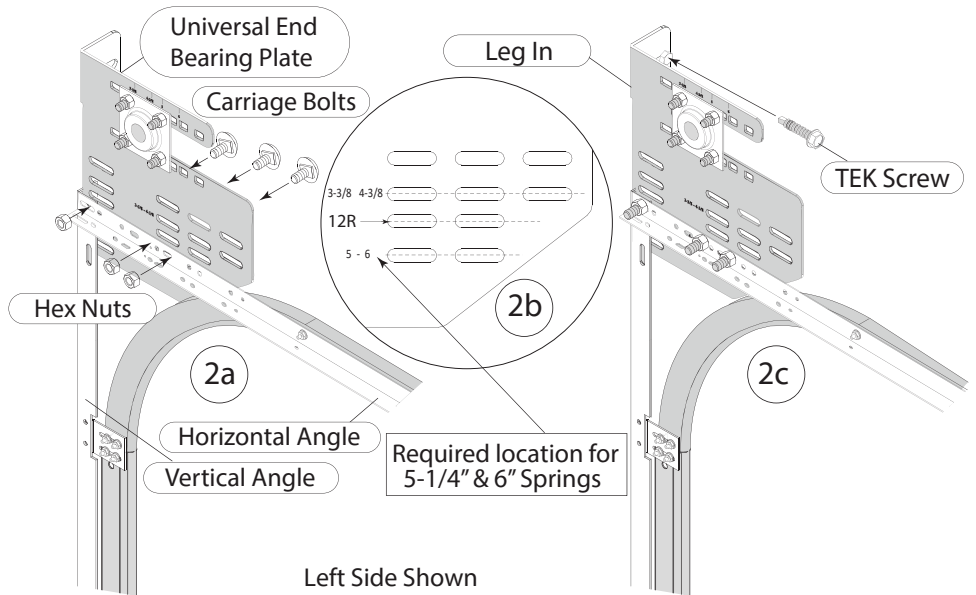

Figure 2

These instructions apply to:

- Standard Lift
- High Lift (max. 72")
- Angle Mount, Leg In shown
- Also Leg Out and Bracket Mount

Instructions for other spring applications may be found in the Supplemental Instructions and/or supplied with springs.

⚠️WARNING Strike Hazard

ONLY use approved winding bars to wind the springs. Failure to secure the track or spring pad could result in death or serious bodily injury.

⚠️WARNING

Do not attach Track or Spring components directly to sheet rock. Always use #2 Yellow Pine or better for Jamb and Spring Pad.

⚠️WARNING Strike Hazard
ONLY use approved winding bars to wind the springs. Failure to secure the track or spring pad could result in death or serious bodily injury.

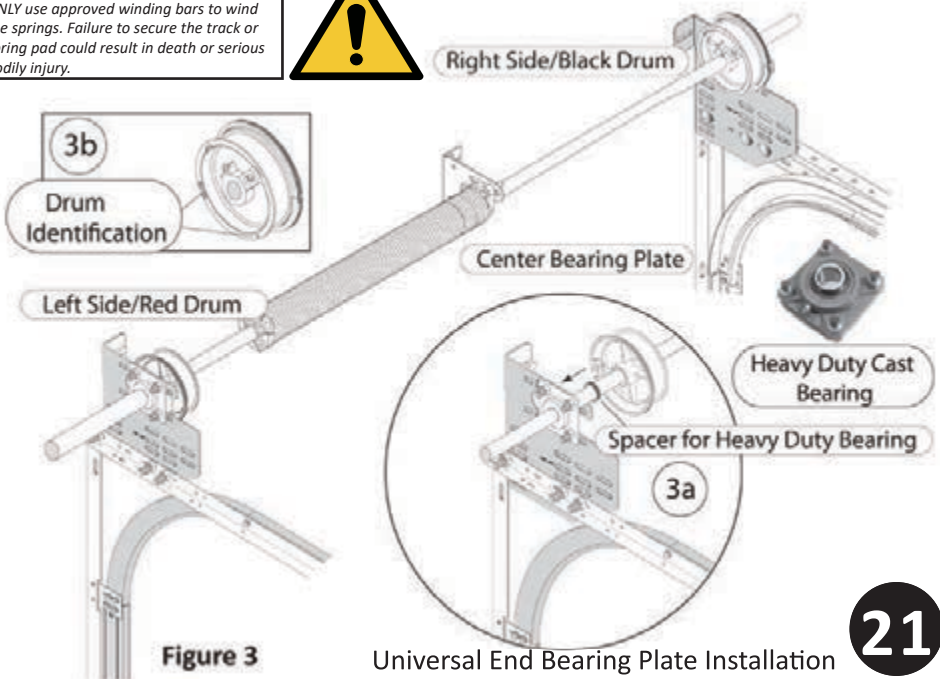

Figure 3

Universal End Bearing Plate Installation

Torsion Spring Growth

Note: Garage doors may be supplied with 1 or more Torsion Springs. Directions for installation are the same.

As turns are added to any Torsion Spring, the spring will increase in length. If the spring is not allowed to grow in length or is allowed to stretch too far, it can create issues such as snaking and pre-mature spring wear.

Step 1: Determining the correct amount of Spring Growth

The formula for determining Spring Growth is:

$$\text{Number of turns required} + 1 \times \text{Wire Size}$$

For example:

A 10' tall, Standard Lift door would require 10.5 turns.

$$10.5 + 1 = 11.5$$

$$11.5 \times .243 \text{ (for example)} = 2.79" - \text{Correct Amount of Spring Growth}$$

Note: DO NOT remove warning label (hang tag) from the center bearing plate.



Step 2: Preparing for Spring Growth

Mark the torsion shaft the distance determined for your spring and number of turns. Place locking pliers at that point to keep spring from exceeding that length.

Note: It is important that the spring does grow to this pre-determined length. You may need to pull the spring slightly after winding.

Step 3: Winding the Torsion Spring

Continue from Page 23 - Winding Torsion Springs

When you have finished winding the Torsion Spring(s), remove the lock Pliers and continue with your installation.

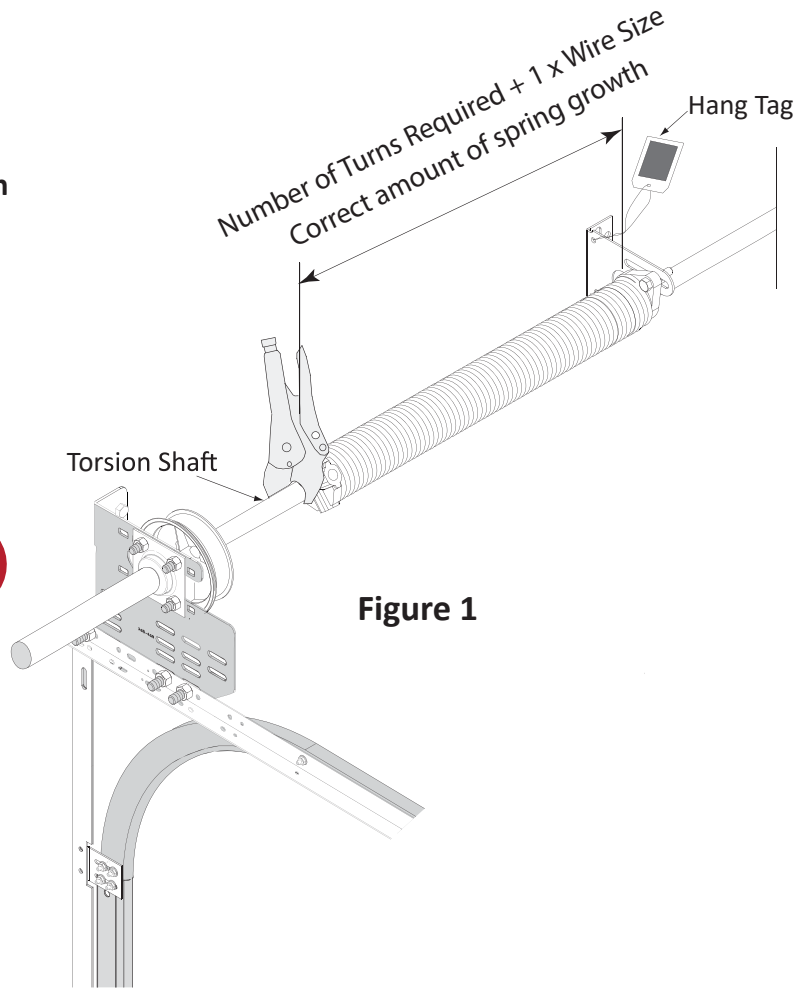

WARNING

High Spring Tension

DO NOT remove, repair or adjust springs or anything to which garage door springs are fastened, such as wood blocks, steel brackets, cables or other like items. Failure to follow these instructions could result in death or serious bodily injury. Repairs and adjustments must be made by a trained door system technician using proper tools and instructions.

Torsion Spring Installation Instructions

Note A: Doors may be supplied with 1, 2 or 4 Torsion Springs. Directions for installation are the same (Figure 4).

Note B: Installation instructions for Low Headroom Torsion to the Rear may be found on Page 33.

Step 1: Torsion Spring Unit Installation

Slide the left side (Red) drum onto the shaft. The Set Screws should be facing toward the center of the shaft. Next, slide the left side Torsion Spring (Red) onto the shaft with the set screws facing toward the left side drum, then slide the Steel Bearing onto the shaft (the Steel Bearing should be turned so it is able to slide into the spring, Figure 1a). If your door requires (2) springs slide the Right/Black spring on facing in the opposite direction of the Left/Red spring. Slide on the right side (Right/Black) drum with the set screws facing toward the middle.

Step 2: Installing the Torsion Spring Unit

Keeping the shaft level, slide the complete Torsion Unit Assembly into the Left and then Right side End Bearing Plates (Figure 1). There should be an equal amount of the shaft protruding from each End Bearing Plate (Figure 1).

Note C: Step 3 refers to a single Spring Pad application. Your Job Specific Shop Drawing (JSSD) provides details.

Step 3: Installing the Center Bearing Plate

The Center Bearing Plate must be mounted in the center of the shaft, and level with the End Bearing Plates so the shaft is level. Fasten the Center Bearing Plate to the Spring Anchor Pad (Figure 1b) with:

(2) 5/16" x 1" IHWH TEK Screws (Mount to Steel)

(2) 5/16" x 1-5/8" Lag Bolts (Mount to Wood)

Step 4: Installing the Spring(s)

Do not remove the Warning Label from the Center Bearing Plate. Slide the spring against the Center Bearing Plate, with the Steel Bearing inserted into the spring (Figure 1a). Using (2) 3/8"x1-1/2" Bolts and (2) 3/8-16 RED Hex Nuts, fasten the spring(s) to the Center Bearing Plate (Figure 1c). If two springs are required, the bolts go through both Springs cones and the Center Bearing Plate. Tighten securely.

Step 5: Installing the Lift Cables

Bring the Left Side Lift Cable up between the door and the track, behind the Torsion Shaft and over the Left Side Drum. Slide the drum against the End Bearing Plate. Hook the Cable Stop into the notch on the outside edge of the drum (Figure 2). Turn the drum with your hand until the cable is snug.

Using only your fingers, tighten the (2) Set Screws on the drum until the Set Screws come in contact with the torsion shaft. Then, turn each screw 1/2 to 1 turn with a wrench.

Note D: Do not over tighten the Set Screws, this could damage the Torsion Shaft.

Using a pair of Lock Pliers, clamp the shaft from the outside of the End Bearing Plate, so that the cable does not loosen or unwind (Figure 2). The back of the Lock Pliers should rest solidly against the jamb/header. This will prevent the drum from unwinding or rising up as you wind the spring. The cables must remain tight, drums must be synchronized with equal turns.

Repeat Step 5 for the Right Side Cables and Drum.



Note: DO NOT remove warning label (hang tag) from the center bearing plate.

Step 6: Winding the Torsion Spring(s)

Mark a straight line on the Spring(s) with a piece of chalk (Figure 3, Step 1). Insert the Winding Bars completely into the full depth of the holes in the Winding Cone.

Note E: Do not remove one Winding Bar until the other is completely seated into the full depth of the hole and you have a firm grip and complete control of the other Winding Bar.

Always wind pushing the Winding Bars up (Figure 3, Step 2) 1/4 turn at a time. When the correct number of turns are on the spring(s) (Figure 3), keeping tension on the spring(s) with the Winding Bar, tighten the Set Screws until Set Screw make contact with the shaft, then tighten one full additional turn.

Note F: Do not over tighten the Set Screws, this could damage the Torsion Shaft.

Very carefully remove the Winding Bars and the Lock Pliers.

Note G: There should be no tension on the Winding Bars.

Standing on the ground, test your installation by working the door up and down. The door should balance (not go up or down) through the complete travel of the door. If the door does not balance, additional or fewer turns may be required. Regrip the Lock Pliers to the Torsion Shaft and add or subtract the appropriate turns.

Proceed to page 16, Step 25 to finish with the installation.

Torsion Spring Installation Instructions

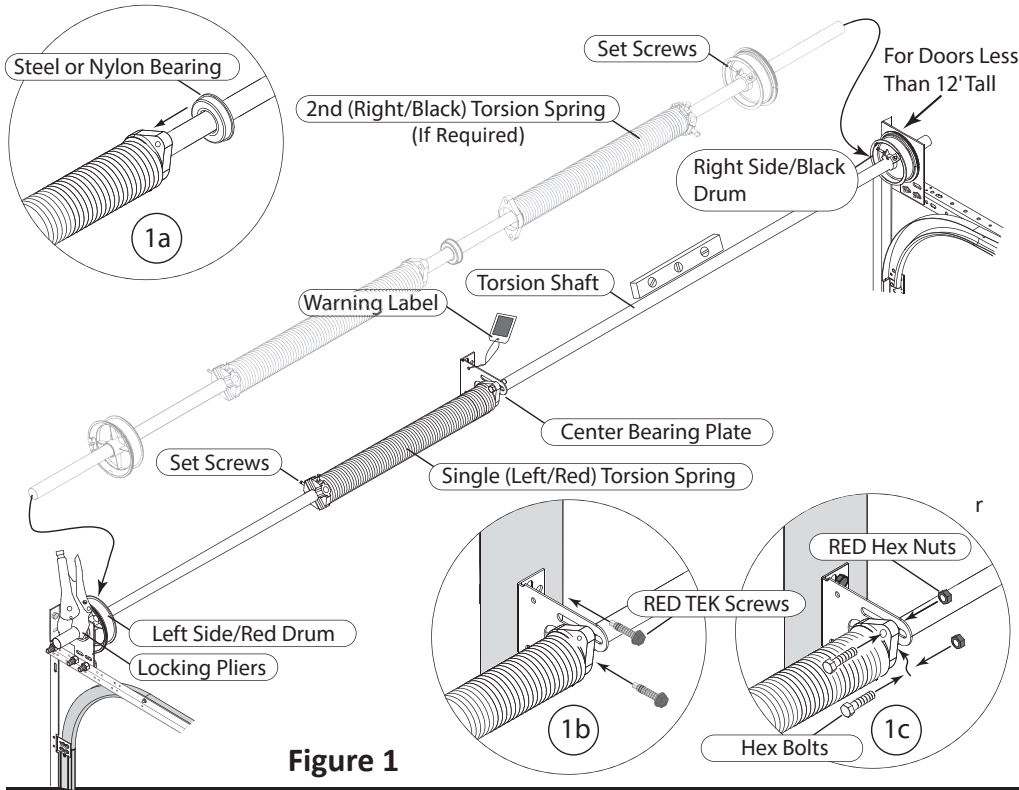

⚠️WARNING Do not attach Track or Spring components directly to sheet rock. Always use #2 Yellow Pine or better for Jamb and Spring Pad.

Note: Number and size of springs, number of bearing plates and spring pads may change. Installing and winding the individual springs remains basically the same.

Figure 1

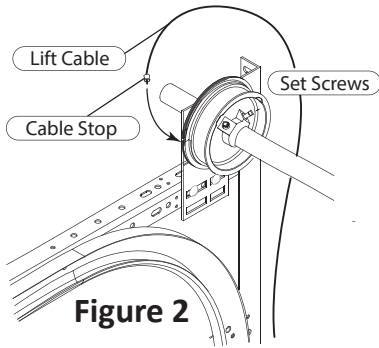

Figure 2

⚠️WARNING High Spring Tension
DO NOT remove, repair or adjust springs or anything to which garage door springs are fastened, such as wood blocks, steel brackets, cables or other like items. Failure to follow these instructions could result in death or serious bodily injury. Repairs and adjustments must be made by a trained door system technician using proper tools and instructions.

⚠️WARNING Strike Hazard
ONLY use approved winding bars to wind the springs. Failure to secure the track or spring pad could result in death or serious bodily injury.

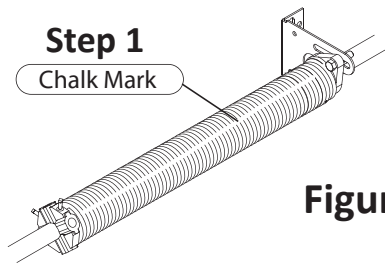
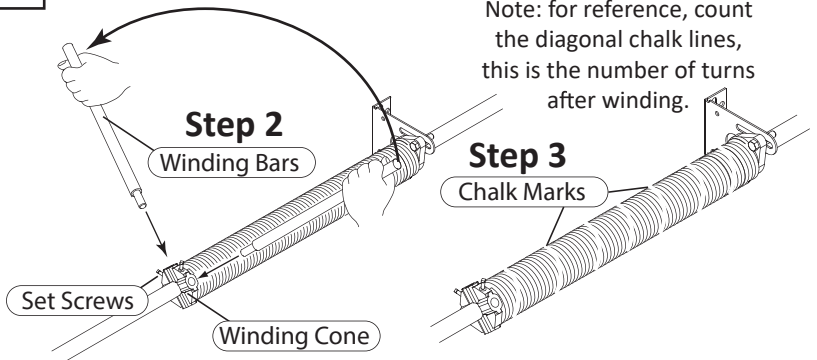

Figure 3

Note: for reference, count the diagonal chalk lines, this is the number of turns after winding.



Stand to the side when winding

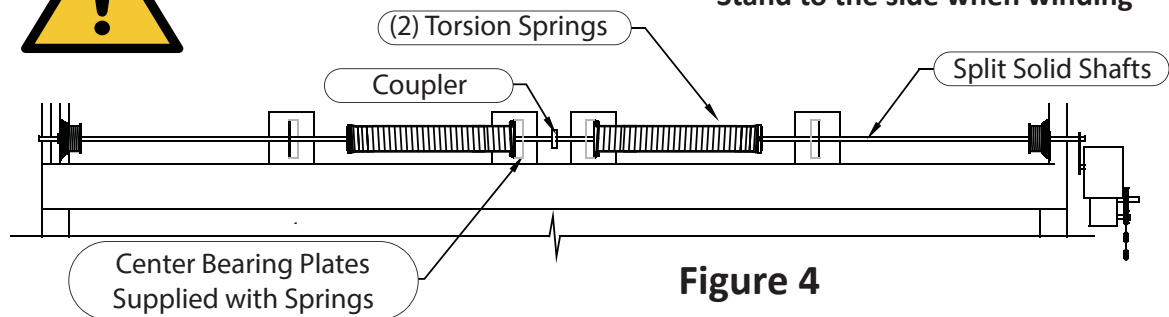

Figure 4

(2) Spring / Split Solid Shaft / (2) Center Bearing Plate
Torsion Power Unit Application (Example)

Examples of Torsion Spring Power Unit Details

(Contact Amarr Engineering for details specific to your application)

(1) SPRING / SINGLE CBP / TORSION POWER UNIT

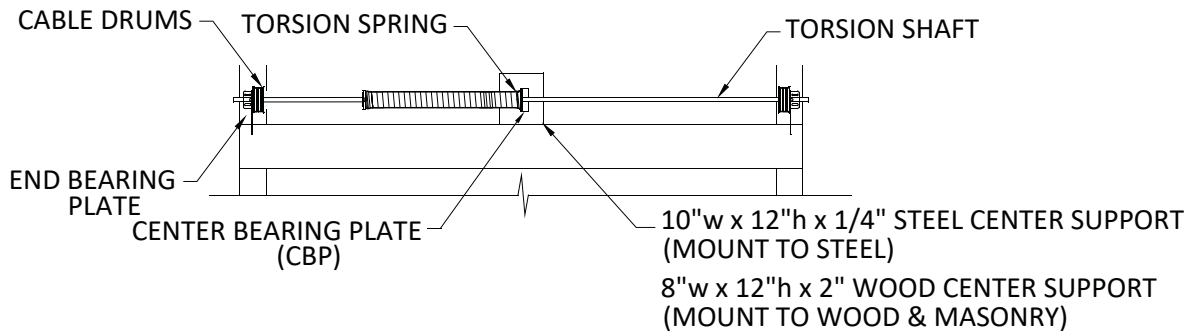

(2) SPRING / SINGLE CBP / TORSION POWER UNIT

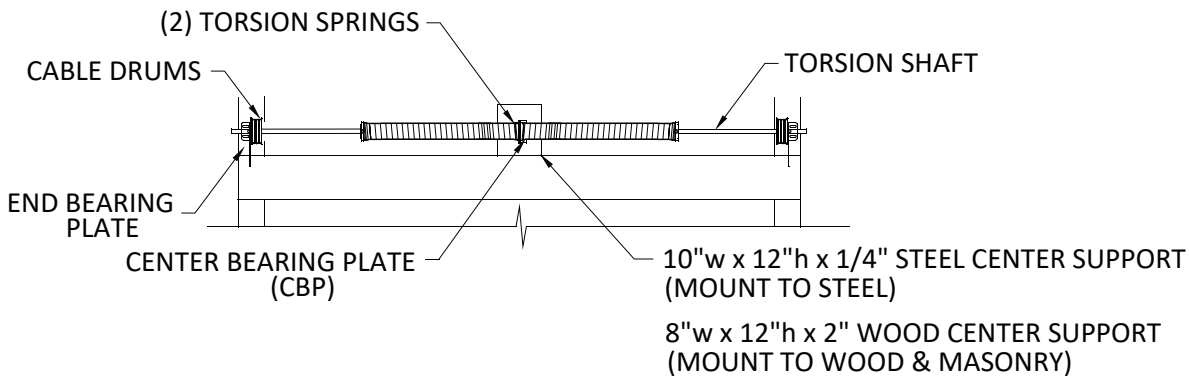

(2) SPRING / SPLIT SOLID SHAFT / (2) CBP / TORSION POWER UNIT

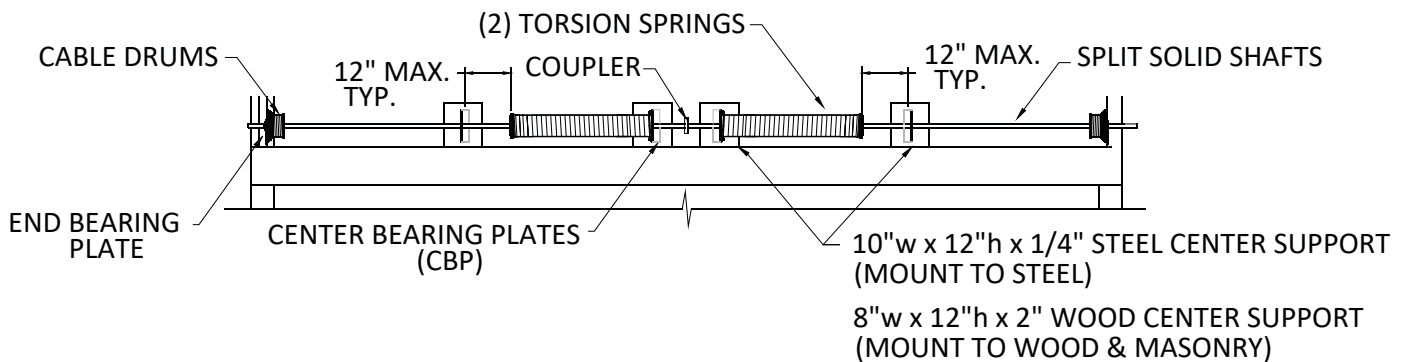

(4) SPRING / SPLIT SOLID SHAFT / (4) CBP / TORSION POWER UNIT

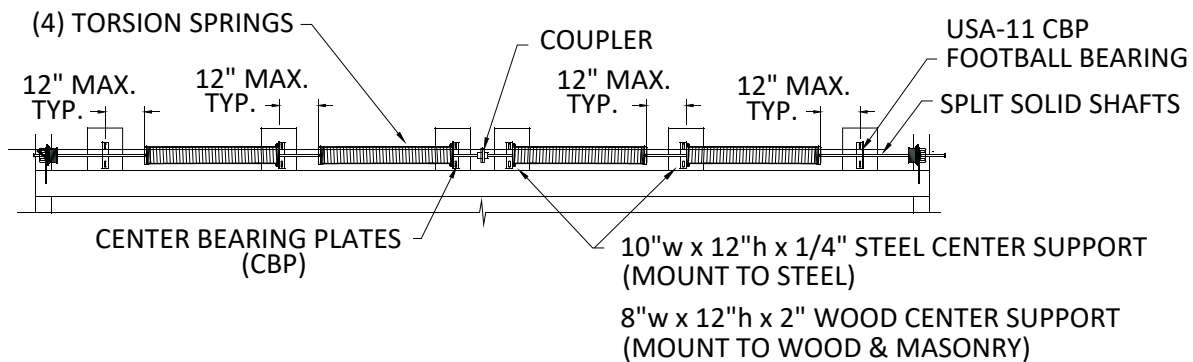

Examples of Torsion Spring Power Unit Details

(Contact Amarr Engineering for details specific to your application)



⚠️ WARNING *High Spring Tension*

DO NOT remove, repair or adjust springs or anything to which garage door springs are fastened, such as wood blocks, steel brackets, cables or other like items. Failure to follow these instructions could result in death or serious bodily injury. Repairs and adjustments must be made by a trained door system technician using proper tools and instructions.

⚠️ WARNING *Strike Hazard*

*The track and spring pad MUST be securely anchored to the wall. Failure to secure the track or spring pad could result in death or serious bodily injury.
DO NOT use nails to secure the track or spring pad.
See Figure 1, page 6.*

Track Hanger Installation Instructions

Track Parallel to Joists

Note: Garage doors are not supplied with Back Hanger or fasteners. These items must be purchased separately.

Note: Hanger Angles must be a minimum of 14 gauge.

Step 1: (right side shown) Keeping the horizontal track square, level, and parallel to each other, mark a spot on your ceiling joist directly above the end of the horizontal track (Figure 1).

Step 2: Mark and cut a piece of angle to span the distance between the ceiling joists / beams plus 4" (Figures 2, 6 & 7).

Step 3: Predrill the two 3/16" holes (Figure 3).

Step 4: Securely fasten each end of the angle to the ceiling joists / beams using:

(2) 5/16" x 1-5/8" Lag Bolts (Wood),

(2) 5/16" x 1" IHWH TEK Screws (Steel) (Figure 4).

Step 5: Measure the distance from the bottom of the Horizontal Track to the top of the angle (Figure 5).

Mark and cut a piece of angle this distance (Figures 6 & 7).

Step 6: Mark and cut a piece of angle to form a 45° brace (Figures 6, 7 & 8). This piece should be about the same length as the piece in Step 5. Securely fasten the Back Hanger Angles using (3) 3/8"x1-1/2" Machine Bolts and (3) 3/8"-16 Hex Nuts as shown in Figure 8.

Step 7: (Standard Lift) Securely fasten the vertical Back Hanger Angle to the Horizontal Track using (1) 3/8"x1-1/2" Machine Bolt and (1) 3/8"-16 Hex Nut (Figure 9).

Step 7: (Low Head Room) Securely fasten the vertical Back Hanger Angle to the Upper Low Head Room Horizontal Track using (1) 3/8"x1-1/2" Machine Bolt and (1) 3/8"-16 Hex Nut (Figure 10).

Track Perpendicular to Joists

Note: Back Hanger installation is essentially the same but will not span two joists. Skip Step 2 and resume installation at Step 3 using an 18" piece of angle.

Track Hanger Installation Instructions

Track Parallel to Joists

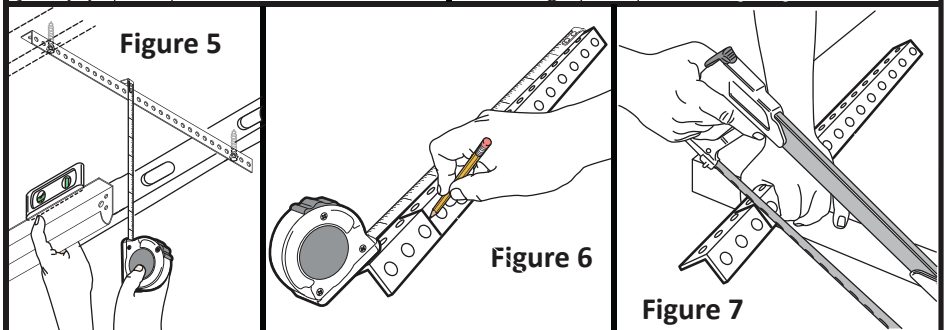
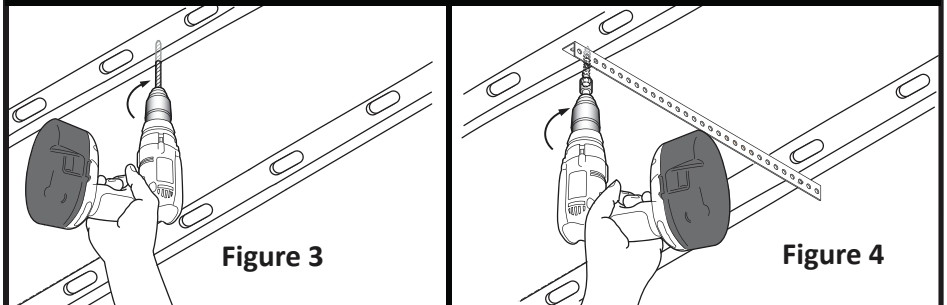
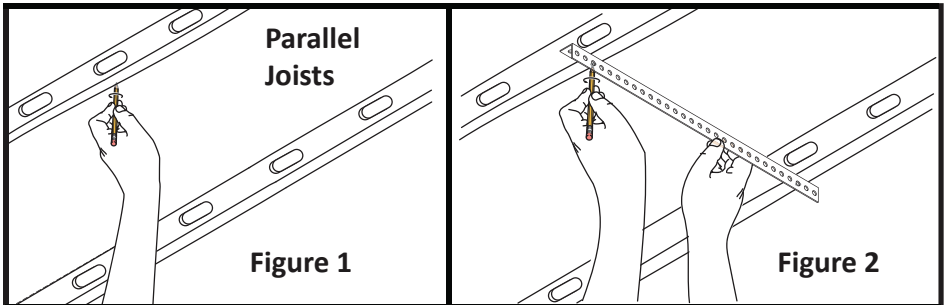

⚠️ WARNING **Overhead Crush Hazard**
 Long end of the threaded bolt must be inside of the track to act as a door stop.

Track Perpendicular to Joists

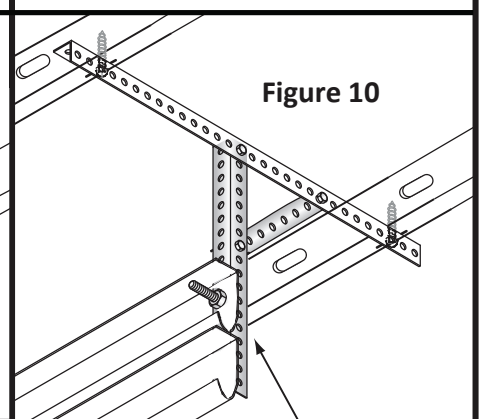
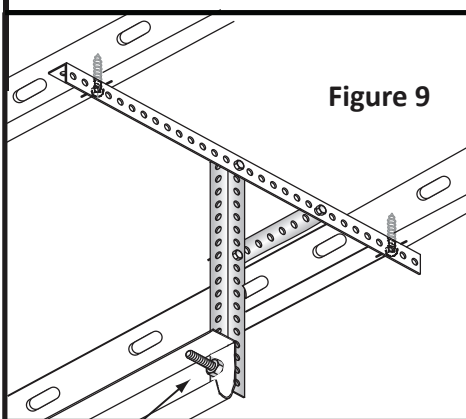
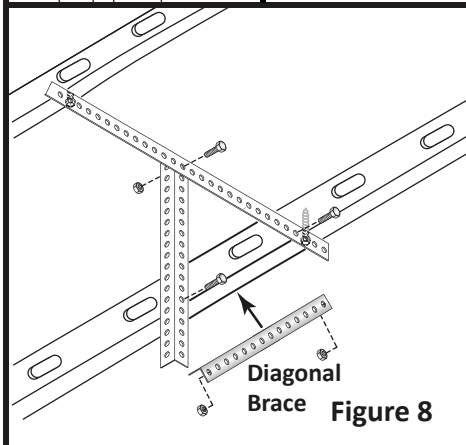
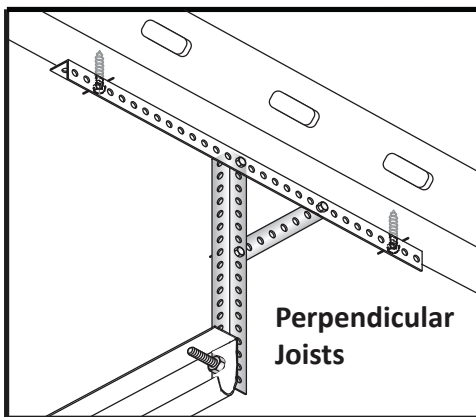

⚠️ WARNING

- Strike Hazard - Sharp Edges
- Risk of death or serious bodily injury
- Track Hanger must not extend below horizontal track

⚠️ WARNING

- Strike Hazard - Risk of Door Falling
- Risk of death or serious bodily injury
- Long end of threaded bolt must be inside of the track to act as a door stop

Slide Lock Installation Instructions

NOTICE

Failure to comply with these instructions invalidates the warranty. Before you begin the installation, read all of the instructions thoroughly.

- Do not install Slide Locks if your garage door is equipped with an Electric Garage Door Opener. 
- Locks (including Slide Locks) will damage your Electric Garage Door Opener and your garage door if the lock is engaged when the operator tries to raise the garage door. This will invalidate the garage door warranty.
- If you are going to install an Electric Garage Door Opener later, remember to remove or disable the Slide Locks. You can disable the lock by opening the dead bolt and putting a lock or bolt through the lock hole (Figure 4).
- It is best to knock out the tab on the track from the inside of the track, before the track is installed.

Note: These instructions show a Double Layer garage door but apply to Single and Triple layer garage doors as well.

Step 1: (Right Side) Using a hammer and punch, knock out the pre-punched rectangular metal tab from the Horizontal Track (Figure 1).

Step 2: With your door in the fully closed position, locate your lock so that the slide will line up with the center of this rectangular hole (Figure 3 & 4). Securely fasten the Slide Lock to the 2nd section with (2) 1/4"x5/8" TEK Screws (Figure 2). You may need to pre-drill 3/32" pilot holes if holes in the section do not line up with this location.

Step 3: With your door in the fully closed/down position, test the Slide Lock for ease of operation. Adjust the lock up or down if necessary (Figure 3 & 4).

If a second lock is requested, repeat Steps 1-3 for the left side.

NOTE: Second lock is not required (non-Wind Load doors).

NOTE: Other locks may be provided with your garage doors. Refer to installation instructions included with the lock for details.

Return to page 16 when installation is complete.

Figure 1

Up to 8' tall

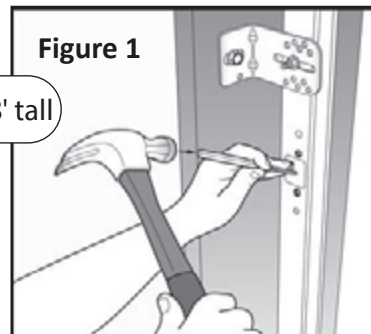

Figure 2

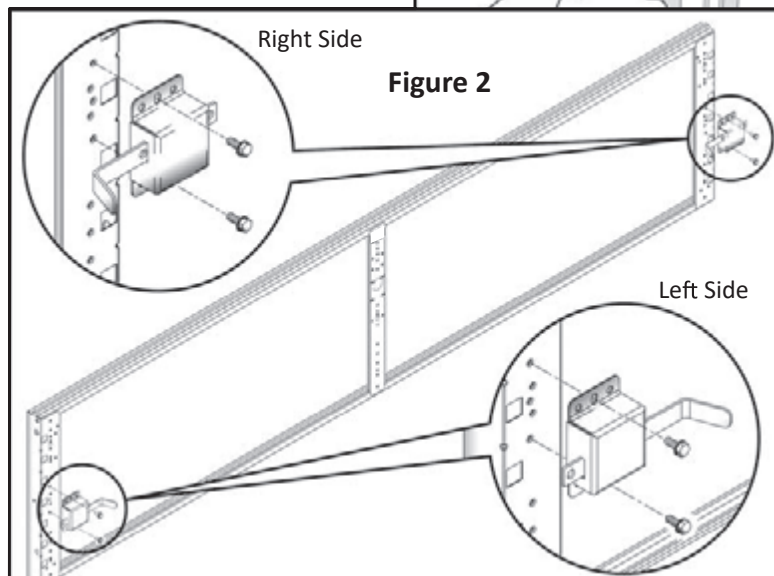

Figure 3

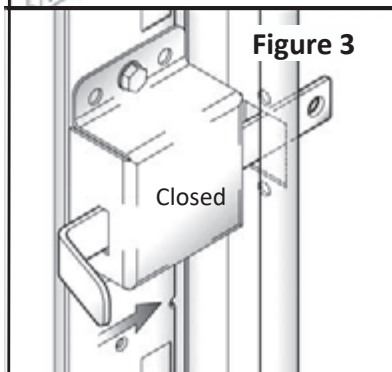
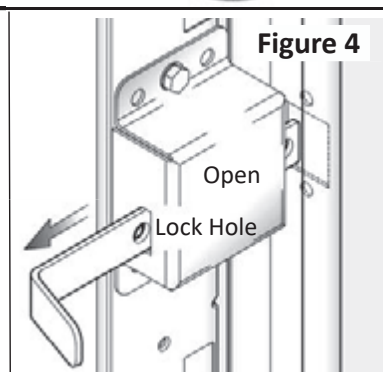

Figure 4



Perimeter Seal Installation Instructions

(Alternative to Jamb Seal)

Note: Garage doors are not supplied with Perimeter Seal or fasteners. These items must be purchased separately.

Note: A Hacksaw is required for smooth, accurate cuts.

Step 1: Measure horizontally across the top of your Header (Figure 1). This may require two people to hold the tape measure.

Step 2: Mark your first piece of Perimeter Seal for cutting (Figure 2).

Step 3: Using a Hack Saw (Figure 3), carefully cut the Perimeter Seal to length.

Step 4: Starting at the end (Figure 4), tap the fasteners halfway into the seal, beginning at 6" from the end and continuing every 12" on center.

Step 5: Holding the seal in place (the edge with the flap (Figure 5 & 6), hammer the fasteners partially into the jamb. This will allow for slight adjustments later.

Step 6: Measure the vertical (left side) of your Jamb (Figure 1). Mark your second piece of Perimeter Seal for cutting (Figure 2).

Step 7: Using a Hack Saw (Figure 3), carefully cut the Perimeter Seal to length.

Step 8: Cut a 45° angle through the molding where it meets the top, horizontal piece (Figure 7). This will allow the flap on the horizontal seal to lay down flush with your door.

Step 9: Starting at the top (Figure 4), tap the fasteners halfway into the seal, beginning at 6" from the top and continuing every 12" on center.

Step 10: Holding the seal in place (the edge with the flap should be flush with the inside of the jamb) (Figure 8), hammer the fasteners partially into the jamb. This will allow for slight adjustments later. Repeat Steps 6 - 10 for the right side Perimeter Seal.

Step 11: When your door is installed, balanced and closed, with either the operator or lock, you may completely nail the Perimeter Seal to the jambs, after making any slight adjustments as required for a tight seal and smooth operation.

Note: If the seal is too tight against the garage door, the door may become difficult to raise and lower, and could result in damage that will void the warranty.

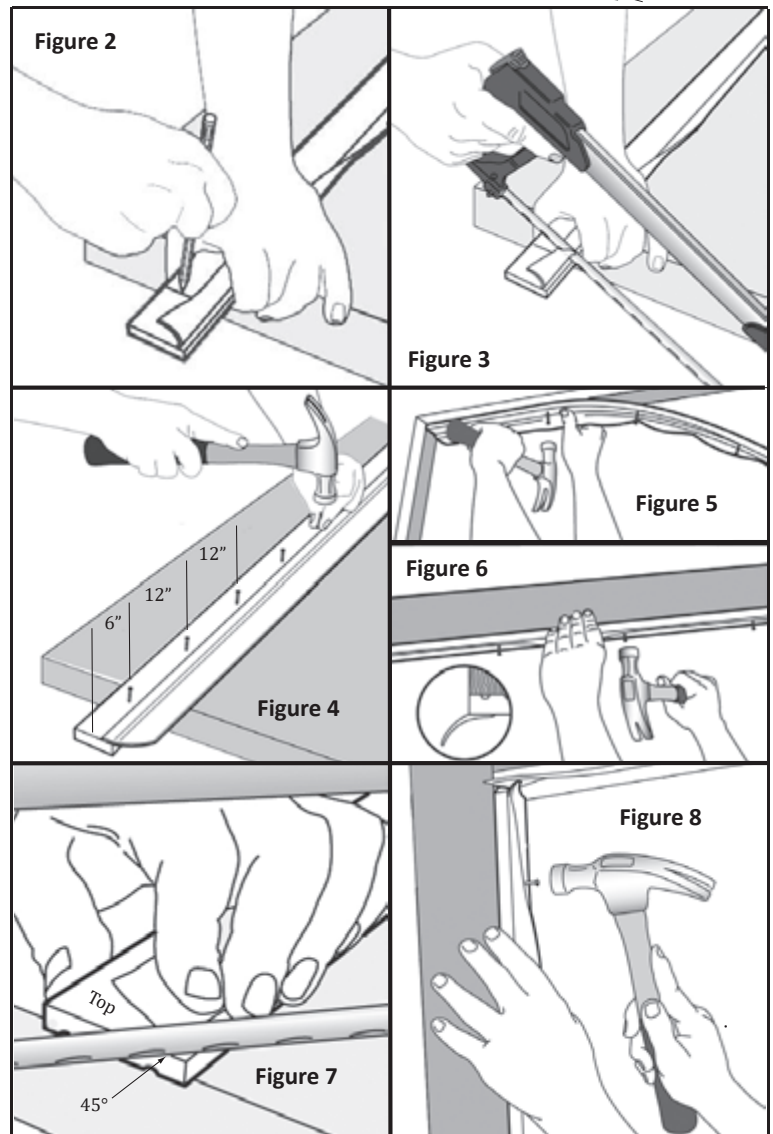
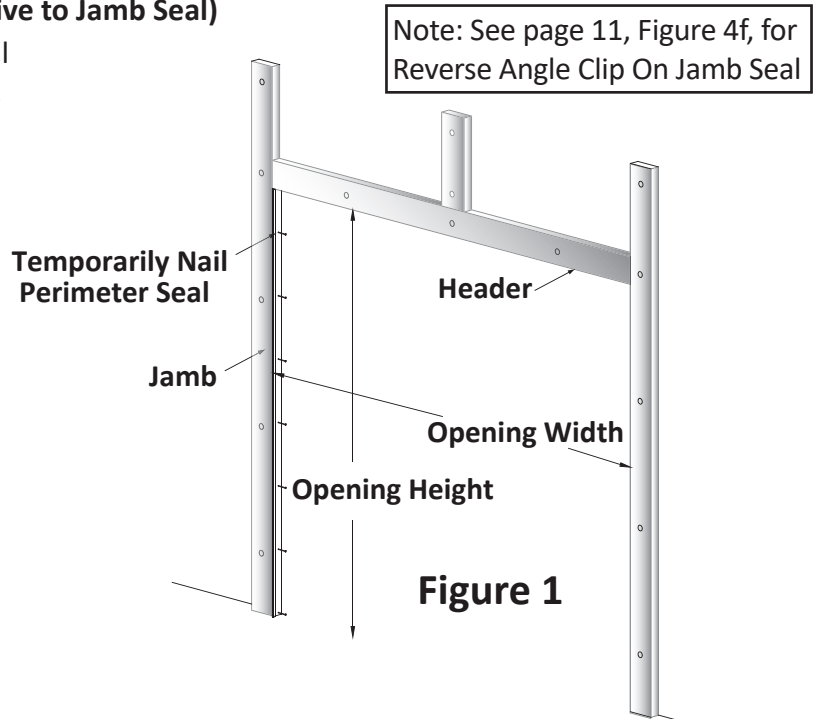

Low Head Room Front (LHF) Track Installation Instructions

Step 1: LH Bottom Bracket Attachment

Place the bottom section face down on a sturdy pair of padded saw horses (Figure 1). Insert the Cable Pin into the hole in the Bottom Bracket, from the inside. Then insert the looped end of the Lift Cable onto the Cable Pin. Push the Cable Pin through the round hole from the inside (Figure 1a). With the Lift Cable securely installed, slide the Cotter Pin through the hole in the Cable Pin, then bend out one leg of the Cotter Pin. Slide the right Bottom Bracket flush to the bottom of the right end stile. Fasten the bracket with (3) 1/4-20 x 1" RED TEK Screws. Insert the Long Stem Roller into the Bottom Bracket.

Repeat Step 1 for the left side LH Bottom Bracket.

Note: The LH Bottom Brackets will be used for Low Headroom Outside Hook Up applications.

Step 2: Horizontal Track to Vertical

Track Attachment (Left Side Assembly shown)

Attach the radius (curved) end of the Horizontal Track Assembly to the Vertical Track with (2) 1/4" x 5/8" Track Splice Bolts and (2) 1/4"-20 Hex Nuts (Figure 2a). Temporarily support the back end of the track using a rope or wire attached to the ceiling.

Note: 1/4"-20 Hex Nuts always go to the outside of the track.

Note: In a Low Head Room installation, only the Top Rollers go into the Upper Horizontal Track. All other Rollers go into the Lower Horizontal Track.

Step 3: Starter Plate to Vertical Angle Attachment

Attach the end of the Starter Plate to the Vertical Angle with (1) 3/8" x 3/4" Low Shoulder Carriage Bolt and (1) 3/8"-16 Hex Nut (Figure 2b).

Note: 3/8"-16 Hex Nuts always go on the outside of the assembly (away from the door).

Step 4: Track Hanger Installation (Figure 2c)

SEE PAGE 27 FOR DETAILS.

Note: Repeat steps 1-3 for Right Side Horizontal Track to Vertical Angle Attachment.

▲WARNING Track needs to be spaced 3/8" - 1/2" from the sections to prevent the sections from falling out of the track.

Step 5: Inspecting the Track Installation

Make sure track is level and square with the opening. Make sure that the distance between the track and the door is the same at the bottom of the vertical track, at the curve of the horizontal, and at the back of the horizontal track (approximately 1/2"). Adjustment to the track position may need to be made later, after the door is opened to maintain the proper spacing.

Step 6: Remove all Temporary Nails

Step 7: Pull Rope Installation

If an electric opener is not used, attach one end of the Pull Rope to the Low Head Room Bottom Bracket and the other end to the second jamb bracket.

For Torsion Spring Installation, go to pages 20 & 23 for details.

Note: Commercial LH front mount requires drums to be moved to the outside, with the Red Drum mounting on the right side and the Black Drum mounted on the left side (Figure 2d).

Low Head Room Front (LHF) Track Installation Instructions

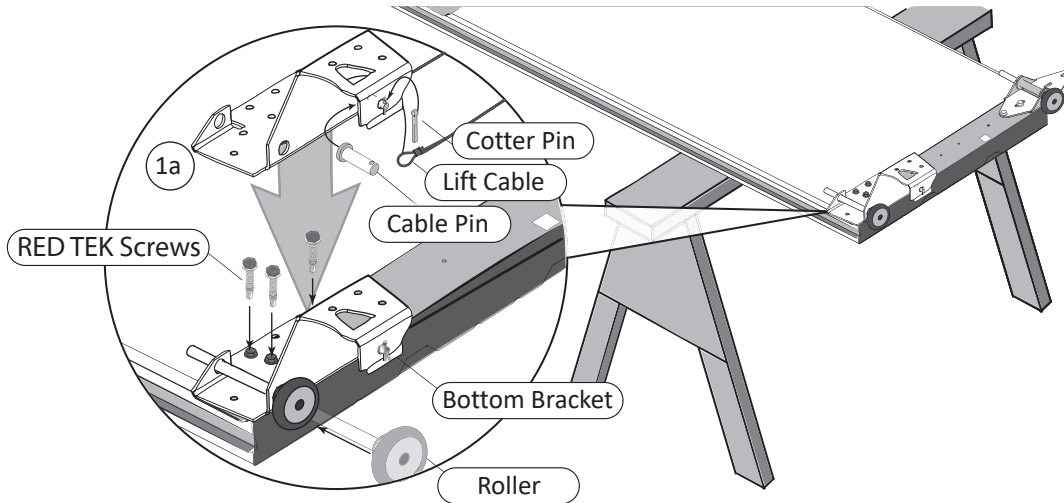

Figure 1

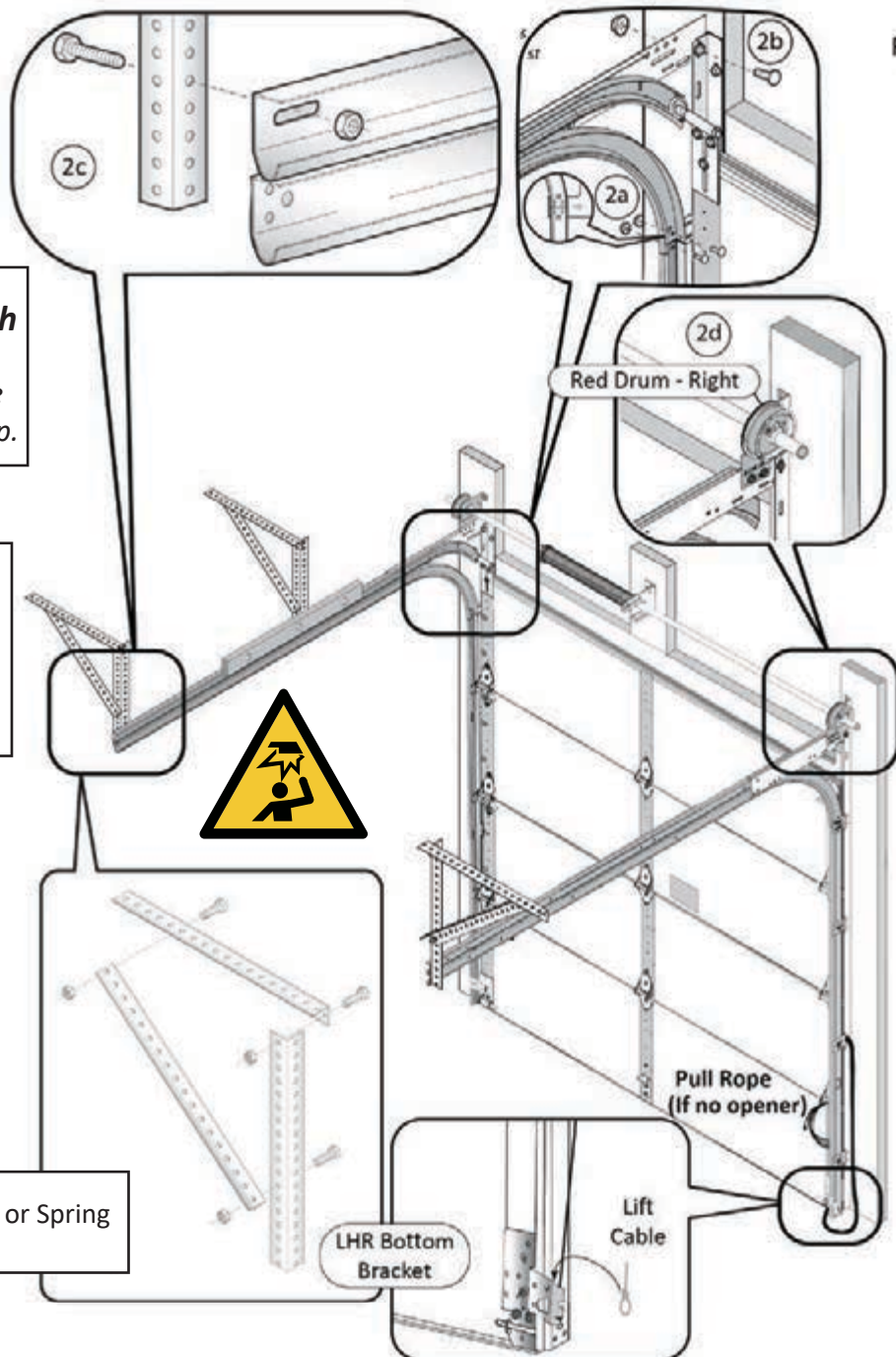

Figure 2

⚠️ WARNING

Overhead Crush Hazard

Long end of the threaded bolt must be inside of the track to act as a door stop.

- Intermediate Hanger required on track and/or doors 11'-16' tall.
- Two Intermediate Hangers required at 16'-18' tall.
- Over 18' tall, no more than 72" between hangers.

⚠️ WARNING

Do not attach Track or Spring components directly to sheet rock.

Low Head Room Rear (LHR) Mount Track Installation Instructions

Step 1: LH Bottom Bracket Attachment

Place the bottom section face down on a sturdy pair of padded saw horses (Figure 1). Insert the Cable Pin into the hole in the Bottom Bracket, from the inside. Then insert the looped end of the Lift Cable onto the Cable Pin. Push the Cable Pin through the round hole from the inside (Figure 1a). With the Lift Cable securely installed, slide the Cotter Pin through the hole in the Cable Pin, then bend out one leg of the Cotter Pin. Slide the right Bottom Bracket flush to the bottom of the right end stile. Fasten the bracket with (3) 1/4-20 x 1" RED TEK Screws. Insert the Long Stem Roller into the Bottom Bracket.

Repeat Step 1 for the left side LH Bottom Bracket.

Note: The LH Bottom Brackets will be used for Low Headroom, Outside Hook Up applications.

Step 2: Attach the Track Hangers as shown on page 27 (left & right). Do not fasten to end of track. Fasten next to the Junction Plate as shown in Fig 2 (right shown).

Note: Track Hanger Angle must not extend beyond the bottom of the lower horizontal track. This may interfere with the cables.

Step 3: Fasten the Right Side Flat End Bearing Plate as shown in Figure 3, using (2) 3/8"x 1-1/2" Machine Bolts and (2) 3/8"-16 Hex Nuts as show (Figure 3). Repeat this step with the Left Side Flat End Bearing Plate.

Step 4: Install the Torsion Shaft with the Spring(s) and Bearing, through the Flat End Bearing Plates (Figure 4).

Note: Springs are reversed due to outside hook-up. Black Cone spring mounts on the left, Red Cone spring mounts on the right.

Step 5: Using the Torsion Shaft as a reference and keeping the shaft level, install an additional Track Hanger assembly to support the Center Bearing Plate (Figure 5).

Note: Install this Track Hanger and Center Bearing Plate as close to the middle of the torsion bar as possible allowing room for an opener if installed.

⚠WARNING Overhead Crush Hazard

Use additional lag bolts or TEK Screws to secure the hanger to the ceiling. Failure to secure the track could result in death or serious bodily injury. Anchor into wood stud or structurally sound member. DO NOT use nails to secure the track or hanger.

Step 6: Attach the Center Bearing Plate to the center Track Hanger with (2) 3/8"x1-1/2" RED Machine Bolts and (2) 3/8"-16 RED Hex Nuts (Figure 5).

Note: Be sure the Torsion Shaft is level.

Step 7: Install the Left Side/Black Cone Spring and Bearing as shown in Figure 5. Attach the spring / springs to the Center Bearing Plate with (2) 3/8"x1-1/2" RED Machine bolts and (2) 3/8"-16 RED Hex nuts.

Step 8: Install the Cable Drum (marked Black) onto the right side of the shaft as shown in Figure 6. Slide the Cable Drum (marked Red) on the left side of the shaft, outside of the track, as shown in the assembled drawing.

Step 9: Attach one Pulley to the Sheave Support (Figure 7A) with (1) 3/8"x1-1/2" RED Machine bolt and (1) 3/8"-16 RED Hex nut.

Repeat for the left side Pulley and Sheave Support.

Step 10: Attach one Pulley and Sheave Support Assembly to the Starter Plate, (Figure 7B) in a slot and hole, between the upper and lower horizontal track, with (2) 1/4-20x1" Machine bolts and (2) 1/4-20 Hex Nuts. Repeat for the left side Sheave Support Assembly.

Step 11: Attach the looped end of the Lift Cable to the right side OHU Bottom Bracket (Figures 1 & 6). Loop the cable over the Pulley and run back under the Drum, inserting the cable stop into the slot in the Drum. Repeat for the left side Drum.

Step 12: Pull Rope Installation

If an electric opener is not used, attach one end of the pull rope to the Bottom Bracket and the other end to the second jamb bracket.

Note: For Spring Installation and Winding details, go to page 23.

Low Head Room Rear (LHR) Mount Track Installation Instructions

- Intermediate Hanger required on track and/or doors 11'-16' tall.
- Two Intermediate Hangers required at 16'-18' tall.
- Over 18' tall, no more than 72" between hangers.

⚠️WARNING

Overhead Crush Hazard

Long end of the threaded bolt must be inside of the track to act as a door stop.

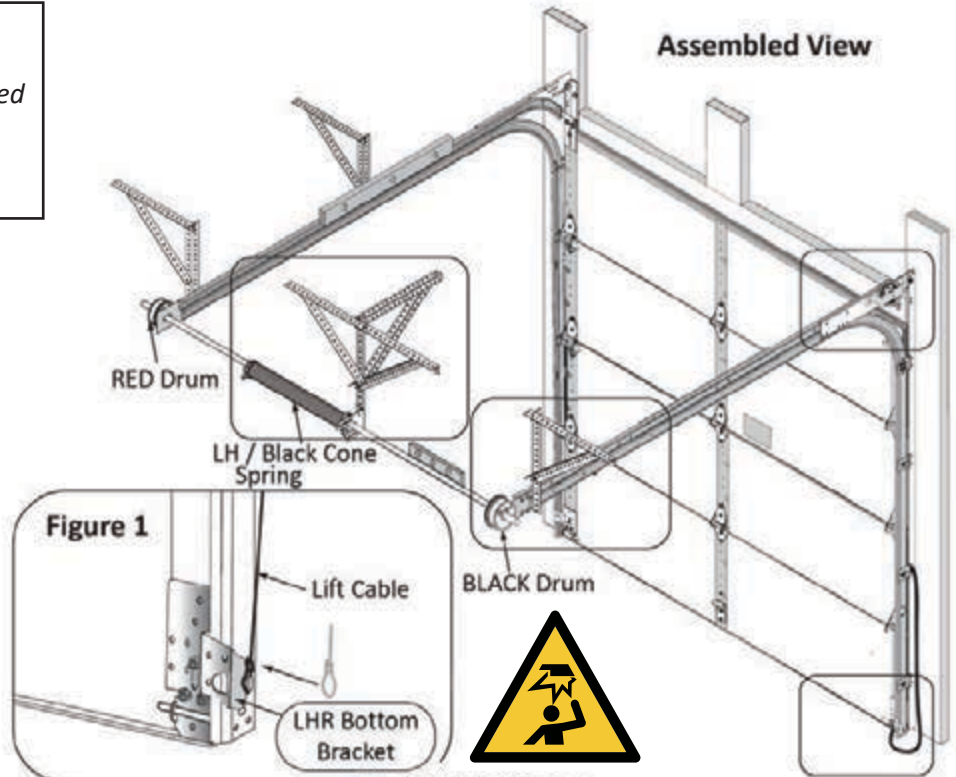

Right Side Shown

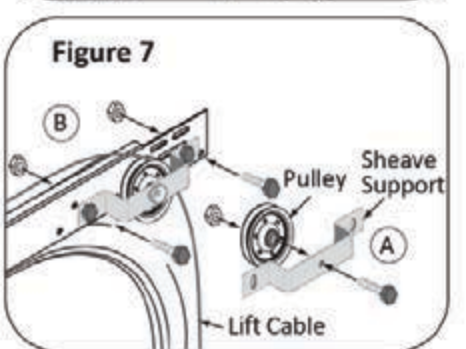
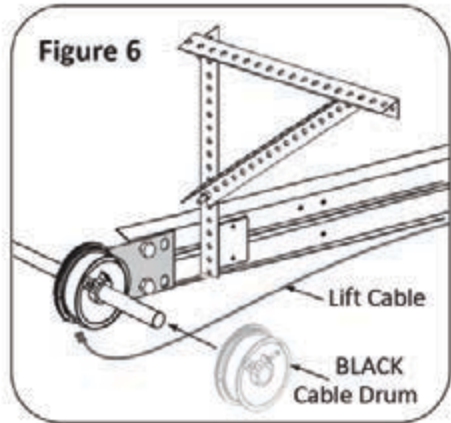
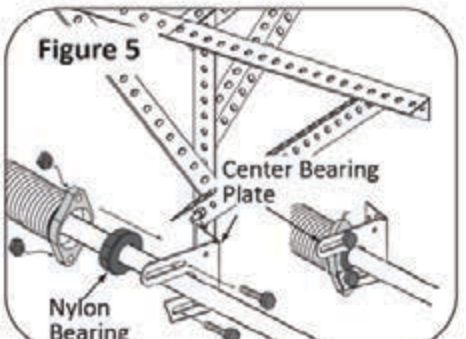
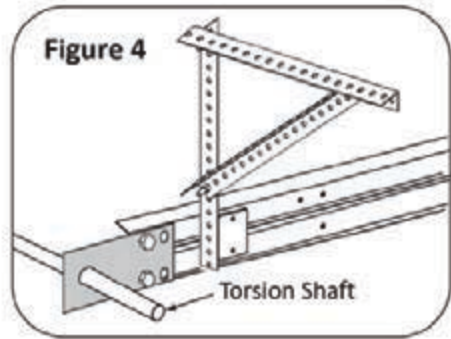
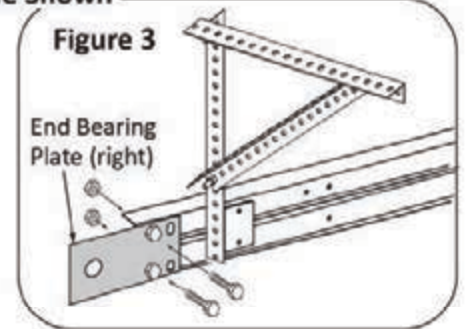
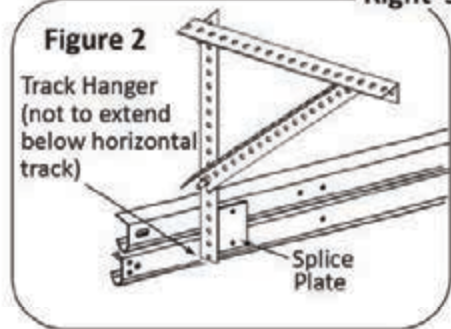

High Lift (HL) Applications Installation Instructions

Note: Vertical Track Assembly should be installed, level and plumb.

Note: Shown is a 48" High Lift Standard, Reverse Angle (leg in) application. Your installation may require leg out, Bracket or 3" Tapered Reverse / Continuous Angle mount to meet your specific jamb application.

Note: Use ladder where required.

Step 1: Installing the Left Side High Lift Assembly (HL). Raise the HL Assembly so that the HL Angle and Track align with the Vertical Track and Angle (Figure 1).

Note: It is important that this track transition be aligned correctly for the rollers to travel smoothly.

Using a level against the HL assembly, be sure the HL assembly is plumb. Pre-drill holes through slots in the angle (using a 3/16" drill bit) to help start the TEK screws into the jamb (Figures 1a & 1b). With the HL assembly properly aligned and plumb, securely attach the HL assembly to the jamb using (2) 1/4"-20 x 1" TEK screws in the Vertical Angle as shown (Figures 1c & 1d).

Continue the process of pre-drilling and attaching 1/4"-20x1" TEK screws through all remaining slots in the angle.

Attach the HL Splice Plate to the Lower and Upper Vertical Angle using (2) 3/8"-16 x 3/4" Low Shoulder Carriage Bolts and (2) 3/8"-16 Hex Nuts (Figure 1e & 1f).

Attach the HL Track to the Splice Plate already attached to the Lower Vertical Angle with (2) 1/4"-20 x 5/8" Track Splice Bolts and (2) 1/4"-20 Hex Nuts (Figures 1g & 1h).

Note: Hex Nuts always go to the outside of the assemblies, away from the door.

Repeat Step 1 for the Right Side High Lift Assembly.

Note: Before beginning this step, assemble the Right and Left side Universal End Bearing Plates (EBP) as shown on page 20, Steps 1-3.

Step 2: Installing the Left Side Horizontal Track and Universal End Bearing Plate Assembly (EBP). Attach the curved end of the Horizontal Assembly to the HL Vertical Assembly with (2) 1/4"-20 x 5/8" Track Splice Bolts and (2) 1/4"-20 Hex Nuts (Figure 2a & 2b). Temporarily support the back end of the track using a rope or wire attached to the ceiling.

Note: It is important to support the back end of the Horizontal Assembly to prevent damaging the track.

Note: The Horizontal Angle will not reach the Vertical Angle as it would in a Standard Lift application (Figure 2c). This is correct.

Attach the EBP to the inside of the Horizontal and Vertical Angle (Figures 2d, 2e & 2f) using (3) 3/8"-16 x 3/4" Low Shoulder Carriage Bolts and (3) 3/8"-16 Hex Nuts.

Pre-drill a hole through slot in the EBP (using a 3/16" drill bit) to help start the TEK screw into the jamb (Figures 2g & 2h). With the Horizontal Track assembly properly aligned and level, securely attach the EBP to the jamb using (1) 1/4"-20 x 1" TEK screw as shown (Figures 2g & 2h).

Repeat Step 2 for the Right Side Horizontal Track and Universal End Bearing Plate Assembly.

⚠WARNING Horizontal Track must be spaced 3/8"-1/2" from the sections to prevent the sections from falling out of the track.

Step 3: Inspecting the Track Installation

Using a tape measure and level, make sure the track is level and square with the opening. Make sure that the distance between the track and the door is equal at the bottom of the Vertical Track, at the curve of the horizontal, and at the back of the Horizontal Track (approximately 3/8"-1/2"). Adjustment to the track position may need to be made later (to maintain the proper spacing) after the springs are installed and the door is opened and closed.

Go to page 16, Step 18: Installing Top Section Hardware, to continue with installation.

Important: After the springs are wound special attention must be taken to assure that the door does not travel past the end of the horizontal tracks.

Bumper Spring Installation - Required

After all sections and springs have been installed and tested for correct operation, Bumper Springs will need to be installed.

Note: Use ladder where required.

Step 1: Installing the Left Side Bumper Spring.

Raise the door the required amount for your application or to the bottom of horizontal jamb.

Step 2: Place the Bumper Spring so that it is making light contact with the top of the section (Figure 3a). Mark or scribe where the holes in the Bumper Spring mounting bracket meet the inside of the track (Figure 3b).

Step 3: Using a 7/16" drill bit, drill (2) holes where marked on the track.

Step 4: Securely fasten the Bumper Spring mounting bracket to the inside of the track using (2) 3/8"-16 x 1-1/4" bolts and (2) 3/8"-16 nuts.

Repeat Steps 1-4 for the Right Side Bumper Spring.

High Lift Applications Installation Instructions

⚠WARNING Do not attach Track or Spring components directly to sheet rock.

⚠WARNING **Overhead Crush Hazard**
 Long end of the threaded bolt must be inside of the track to act as a door stop.

- Intermediate Hanger required on track and/or doors 11'-16' tall.
- Two Intermediate Hangers required at 16'-18' tall.
- Over 18' tall, no more than 72" between hangers.

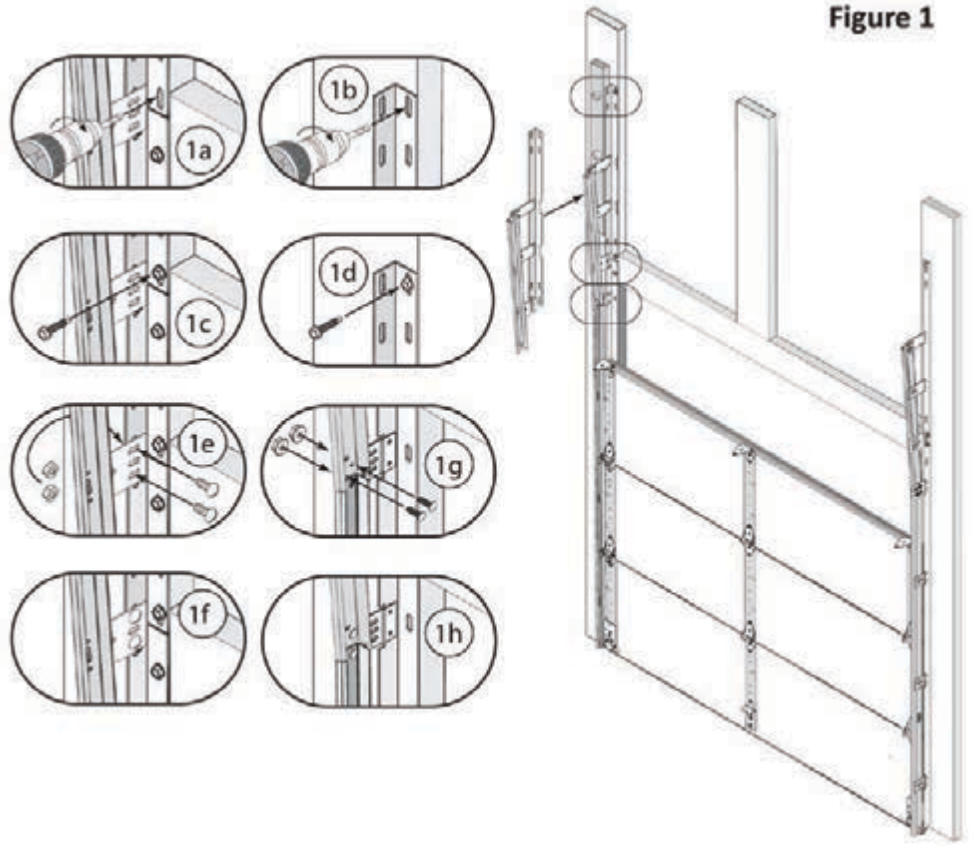

Figure 1

Figure 2

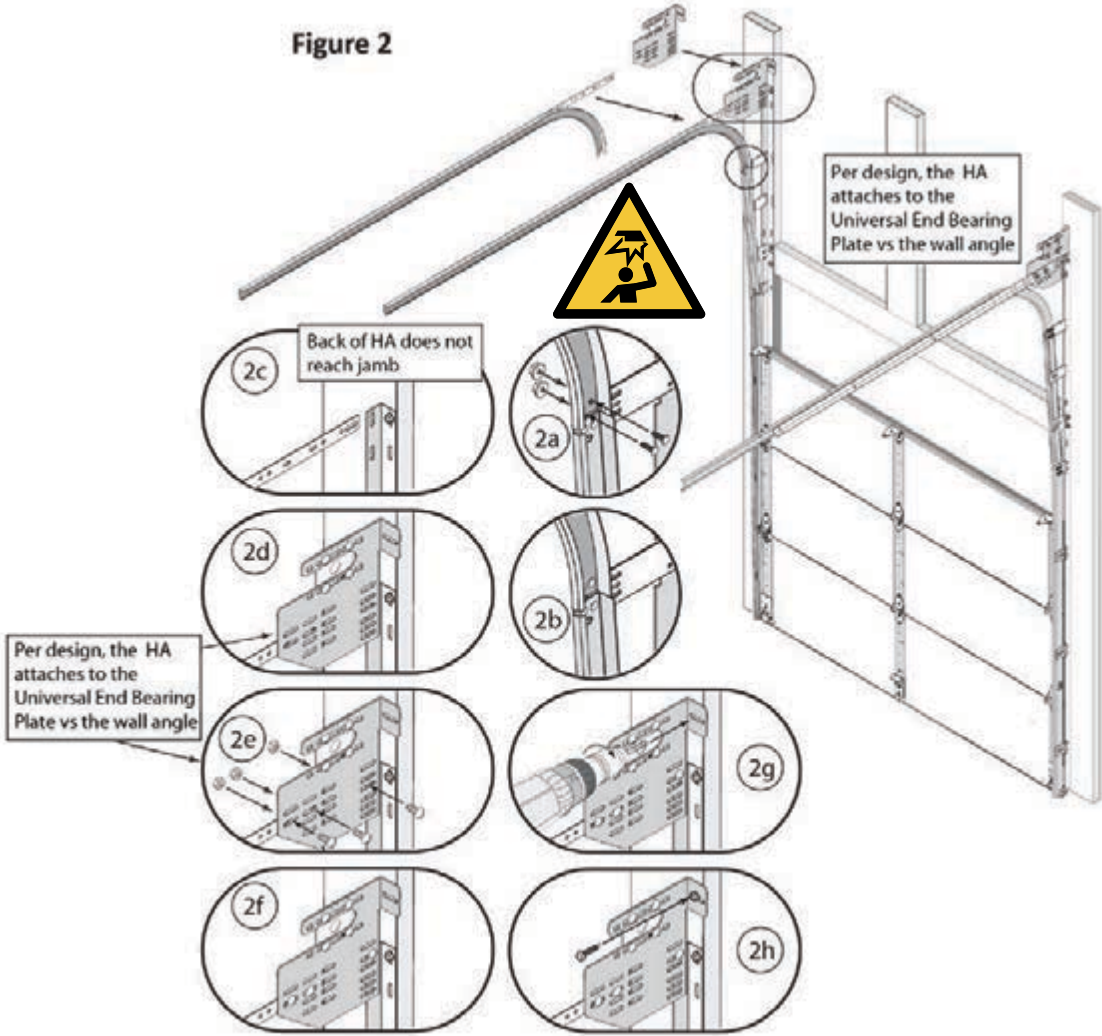
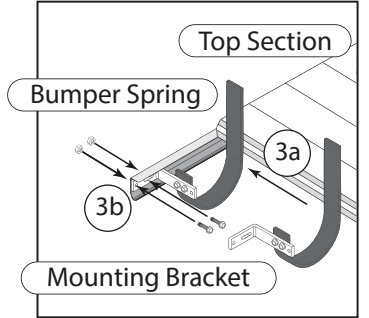

Figure 3



Vertical Lift Applications Installation Instructions

Note: Shown is a Vertical Lift Standard, Reverse Angle (leg in), application. Your installation may require leg out, bracket mount or 3" Tapered Reverse / Continuous Angle mount to meet your specific jamb application. Basic installation will be the same.

Note: Use ladder where required.

Step 1: Installing the Left Side Vertical Lift Assembly (VL). Raise the VL Assembly so that the VL Angle and Track align with the Lower Vertical Track and Angle (Figure 1).

Note: It is important that this track transition, be aligned correctly for the rollers to travel smoothly.

⚠WARNING Horizontal Track must be spaced 3/8" - 1/2" from the sections to prevent the sections from falling out of the track.

Using a level against the VL assembly, be sure the VL assembly is plumb. Pre-drill holes through slots in the angle (using a 3/16" drill bit) to help start the TEK screws into the jamb (Figure 1a & 1b). With the VL assembly properly aligned and plumb, securely attach the VL assembly to the jamb using (2) 1/4-20 x 1" TEK screws in the Vertical Angle as shown (Figures 1c & 1d).

Continue the process of pre-drilling and attaching 1/4-20 x 1" TEK screws through all remaining slots in the angle.

Attach the VL Splice Plate to the Lower and Upper Vertical Angle using (1) 3/8"-16 x 3/4" Low Shoulder Carriage Bolts and (1) 3/8"-16 Hex Nuts (Figures 1e & 1f).

Attach the VL Track to the Splice Plate already attached to the Lower Vertical Angle with (2) 1/4"-20 x 5/8" Track Splice Bolts and (2) 1/4"-20 Hex Nuts (Figures 1g & 1h).

Note: Hex Nuts always go to the outside of the assemblies, away from the door.

Repeat Step 1 for the Right Side Vertical Lift Assembly.

Important: Vertical Track must be spaced 3/8"-1/2" from the sections to prevent the sections from falling out of the track.

Step 2: Inspecting the Track Installation

Using a tape measure and level, make sure the track is level and square with the opening. Make sure that the distance between the track and the door is equal at the bottom of the Vertical Track, and at the top of the Upper Vertical Track (minimum 3/8").

Adjustment to the track position may need to be made later (to maintain the proper spacing) after the springs are installed and the door is opened and closed.

Go to page 16, Step 18: Installing Top Section Hardware, to continue with installation.

Bumper Spring Installation - Required

After all sections and springs have been installed and tested for correct operation, Bumper Springs will need to be installed.

Note: Use ladder where required.

Step 1: Installing the Left Side Bumper Spring

Raise the door the required amount for your application or to the bottom of header.

Important: After the springs are wound special attention must be taken to assure that the door does not travel past the end of the vertical tracks.

Step 2: Place the Bumper Spring so that it is making light contact with the top of the section (Figure 2a). Mark or scribe where the holes in the Bumper Spring mounting bracket meet the inside of the track (Figure 2b).

Step 3: Using a 7/16" drill bit, drill (2) holes where marked on the track.

Step 4: Securely fasten the Bumper Spring mounting bracket to the inside of the track using (2) 3/8"-16x1-1/4" bolts and (2) 3/8"-16 nuts.

Repeat Steps 1-4 for the Right Side Bumper Spring.

Vertical Lift Applications Installation Instructions

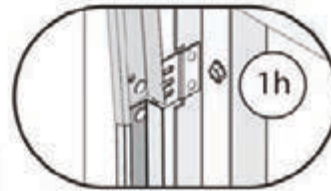
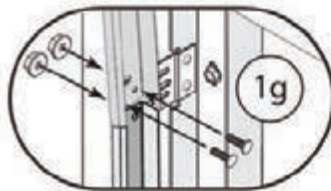
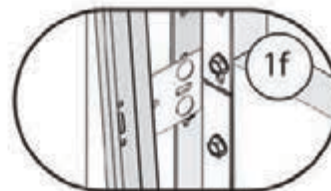
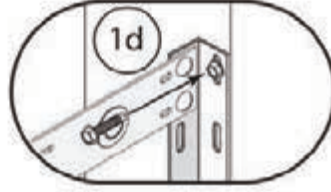
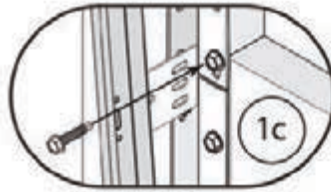
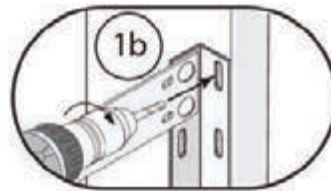
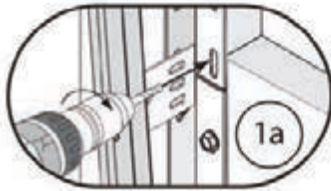

⚠WARNING Do not attach Track or Spring components directly to sheet rock.

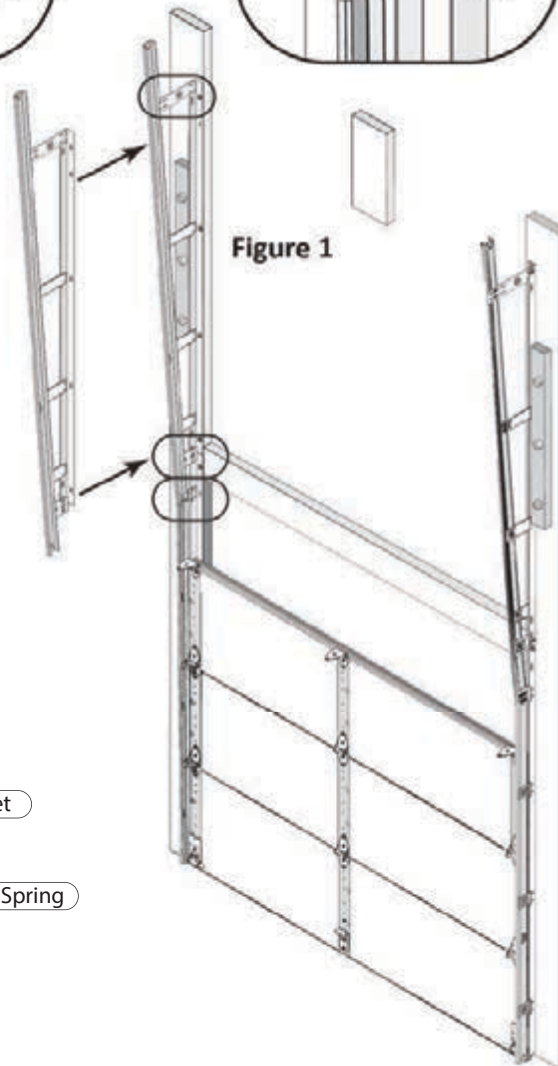

Figure 1

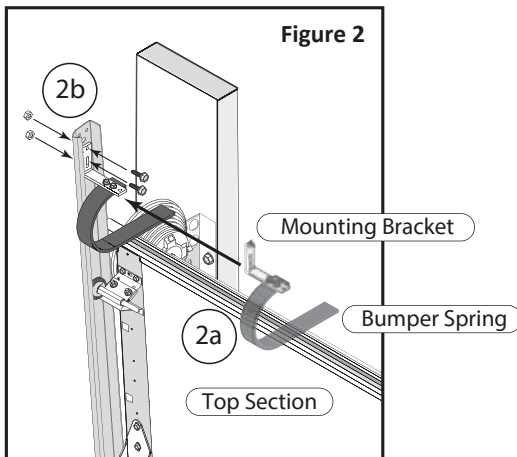
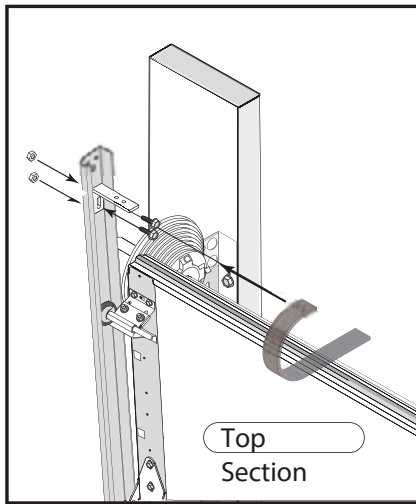
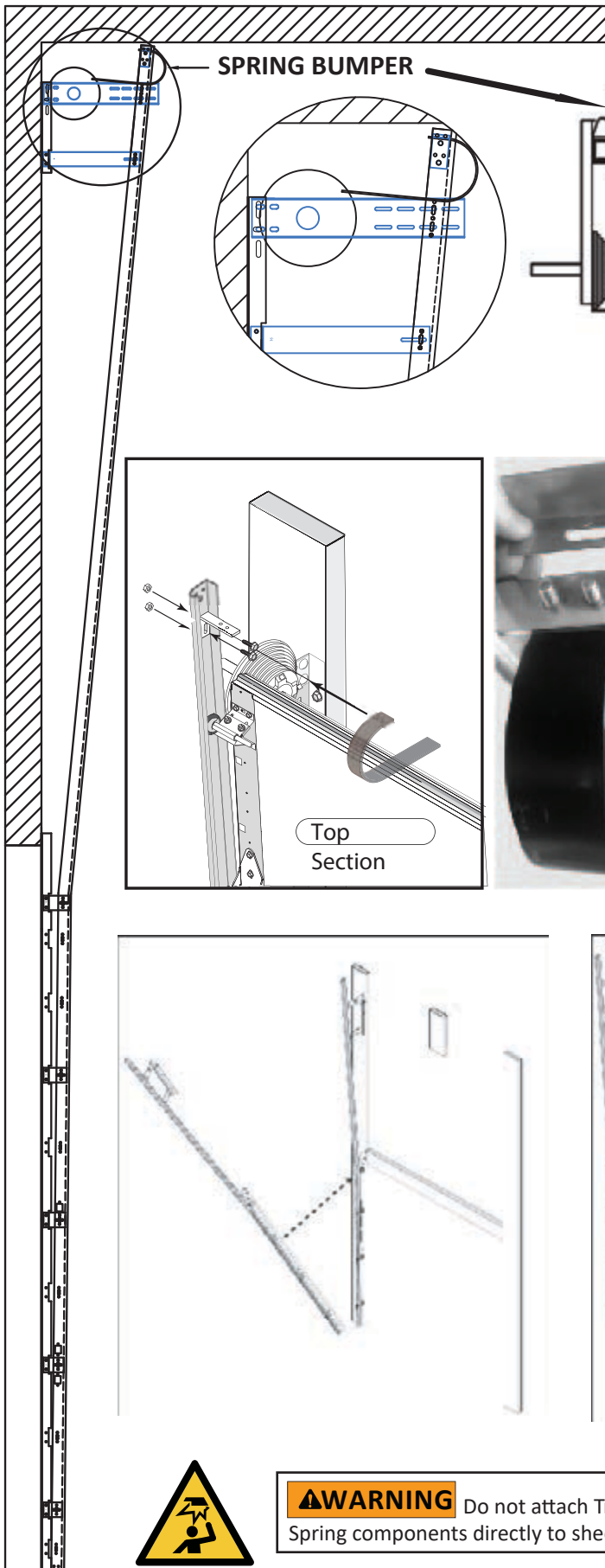
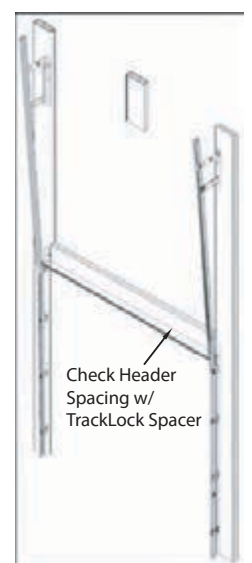

Figure 2

Rapid Install Vertical Lift with TrackLock Spacer Installation Instructions



- Place TrackLock Spacer on top of the Spring Bumper angle. Spring Bumper angle should be positioned leg down, so as to utilize the prepunched hole in the track for positioning.
- The Spring Bumper bolts go through the slot in the TrackLock Spacer.
- Tracklock Spacer should butt against the inside edge of the track.
- Secure the TrackLock Spacer by tightening the Flange Nuts.



⚠WARNING Do not attach Track or Spring components directly to sheet rock.

Follow the Roof Pitch (FTRP) Applications Installation Instructions

Note: Shown is a 4:12 FTRP, Reverse Angle (leg in), application. Your installation may require leg out, bracket mount or 3" tapered reverse / continuous angle mount to meet your specific jamb application.

Note: Use ladder where required.

⚠WARNING Horizontal Track must be spaced 3/8" - 1/2" from the sections to prevent the sections from falling out of the track.

Step 1: Installing the Left Side FTRP Assembly.
Raise the FTRP Assembly so that the FTRP Angle and Track align with the Vertical Track and Angle (Figure 1a).

Note: It is important that this track transition, be aligned correctly for the rollers to travel smoothly.

Attach the curved end of the FTRP Horizontal Assembly to the Vertical Assembly with (2) 1/4"-20 x 5/8" Track Splice Bolts and (2) 1/4"-20 Hex Nuts (Figure 1b). Temporarily support the back end of the track using a rope or wire attached to the ceiling.

Note: It is important to support the back end of the FTRP Horizontal Assembly to prevent damaging the track.

Attach the FTRP Horizontal Angle to the Vertical Angle (Figure 1c) with a 3/8" x 1" Low Shoulder Carriage Bolt and 3/8"-16 Hex Nut. This may require drilling a 1/2" hole through the Vertical Angle.

Note: Hex Nuts always go to the outside of the assemblies, away from the door.

Note: Before beginning this step, assemble the Right and Left side Universal End Bearing Plates (EBP).

Step 2: Installing the Left Side Horizontal Adder Angle and Universal End Bearing Plate Assembly (EBP). Drill a 1/4" hole through the Horizontal Adder Angle and into the FTRP Horizontal Angle and track (Figure 2a). Attach with (1) 1/4"-20 x 5/8" Track Splice Bolt and (1) 1/4"-20 Hex Nuts.

Attach the other end of the Horizontal Adder Angle to the Vertical Angle with (1) 3/8"-16 x 3/4" Low Shoulder Carriage Bolt and (1) 3/8"-16 Hex Nuts (Figure 2b). This nut and bolt may be removed later when installing the EBP.

Attach the EBP to the inside of the Horizontal and Vertical Angle (Figures 2d, 2e & 2f) using (2) 3/8"-16 x 3/4" Low Shoulder Carriage Bolts and (2) 3/8"-16 Hex Nuts (Figure 2c).

Pre-drill a hole through slot in the EBP (using a 3/16" drill bit) to help start the TEK screw into the jamb. With the Horizontal Track assembly properly aligned and level, securely attach the EBP to the jamb using (1) 1/4"-20 x 1" TEK screw as shown (Figure 2d).

Repeat Steps 1 & 2 for the Right Side Horizontal Track and Universal End Bearing Plate Assembly.

Step 3: Inspecting the Track Installation

Using a tape measure and level, make sure the track is square with the opening. Make sure that the distance between the track and the door is equal at the bottom of the Vertical Track, at the curve of the horizontal, and at the back of the Horizontal Track (approximately 1/2"). Adjustment to the track position may need to be made later (to maintain the proper spacing) after the springs are installed and the door is opened and closed.

Go to page 27: Track Hanger Installation, to continue with installation (Figure 2e).

Bumper Spring Installation Required for FTRP with High Lift Installations

Go to page 37 for Bumper Spring Installation Instructions.

Follow the Roof Pitch (FTRP) Applications Installation Instructions

Job Specific Shop Drawings (JSSD) that show the exact FTRP application are recommended. Please contact your supplying Door Center to obtain these drawings.

⚠️WARNING *Overhead Crush Hazard*

Long end of the threaded bolt must be inside of the track to act as a door stop.

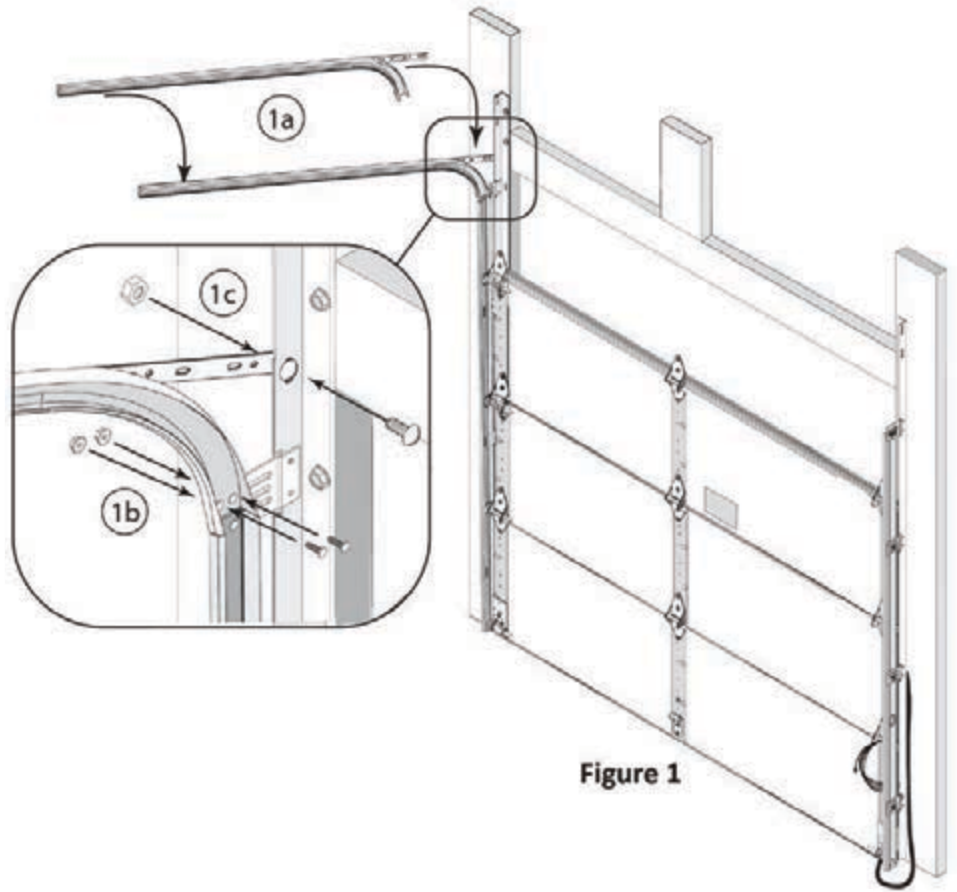

Figure 1

⚠️WARNING Do not attach Track or Spring components directly to sheet rock.

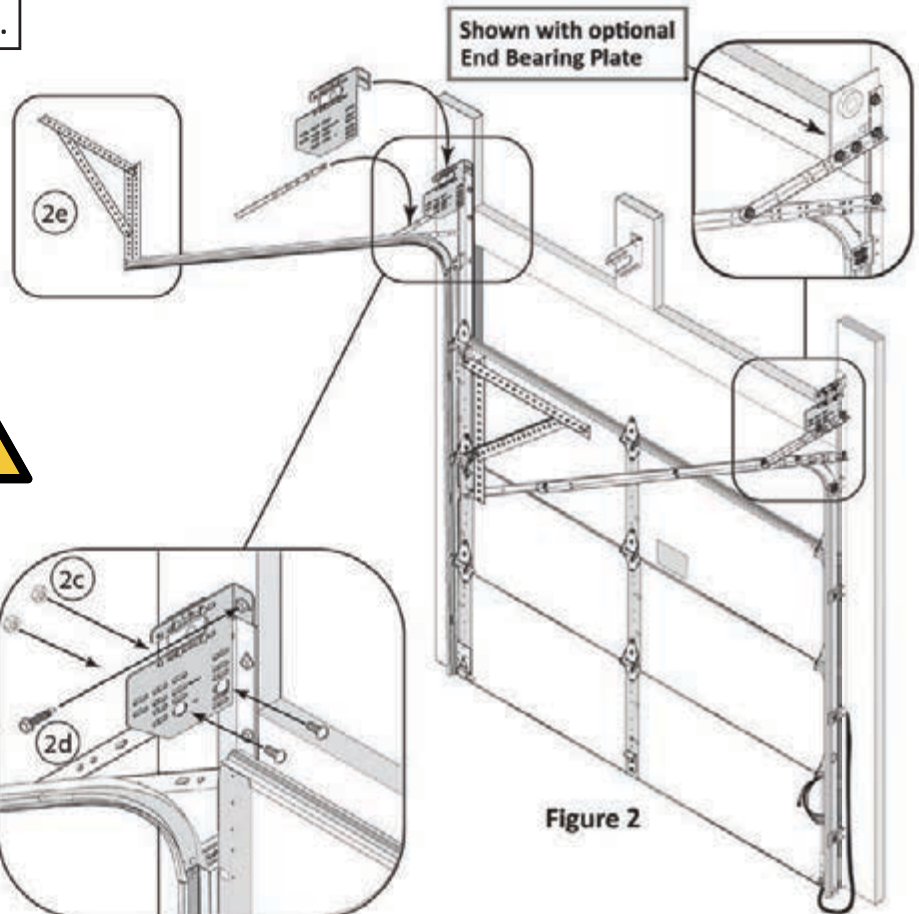
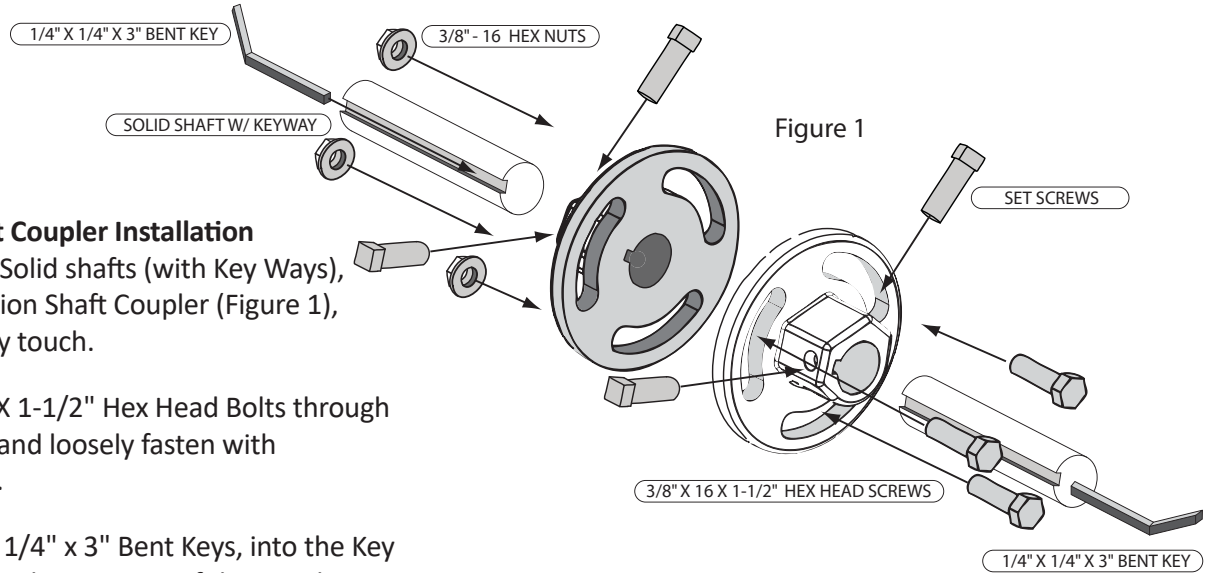

Figure 2

Torsion Shaft Coupler and Drums with Key Way Installation



Torsion Shaft Coupler Installation

Step 1: Align the two Split Solid shafts (with Key Ways), with both sides of the Torsion Shaft Coupler (Figure 1), and slide them in until they touch.

Step 2: Insert (3) 3/8" -16 X 1-1/2" Hex Head Bolts through both sides of the Coupler, and loosely fasten with (3) 3/8"-16 Hex Head nuts.

Step 3: Slide the (2) 1/4" x 1/4" x 3" Bent Keys, into the Key Way of both shafts and into the Key Way of the couplers.

Step 4: Loosely tighten the (2) Set Screws in each side of until finger tight.

Step 5: With the two shafts touching in the middle, between the two sides of the coupler, securely fasten the (3) 3/8"-16 bolts and nuts, and tighten the set screws approximately 1/2 to 1 turn with a wrench (Figure 2).

Note: More than 1 full turn on the Set Screws can damage the coupler and the shaft.

Note: Torque applied to set screws must not exceed 300 in/lbs.

Note: Set Screws must not be installed into an empty keyway, only keyways with Bent Keys.

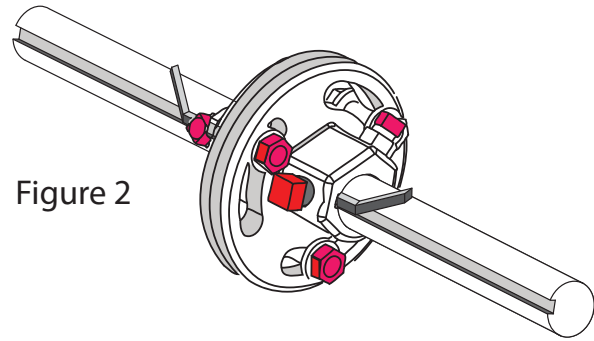

Cable Drums with Key Way Installation

Step 1: Slide the 1/4" X 1/4" X 3" Bent Key, into the Key Way of the shaft and into the Key Way of the drum (Figure 3).

Step 2: Loosely tighten the (2) Set Screws in the drum until nger tight.

Step 3: Tighten the set screws approxiimately 1/2 - 1 turn with a wrench.

Repeat for the other drum.

Note: More than 1 full turn on the Set Screws can damage the drum and the shaft.

Note: Torque applied to set screws must not exceed 300 in/lbs.

Note: Set Screws must not be installed into an empty keyway, only keyways with Bent Keys.

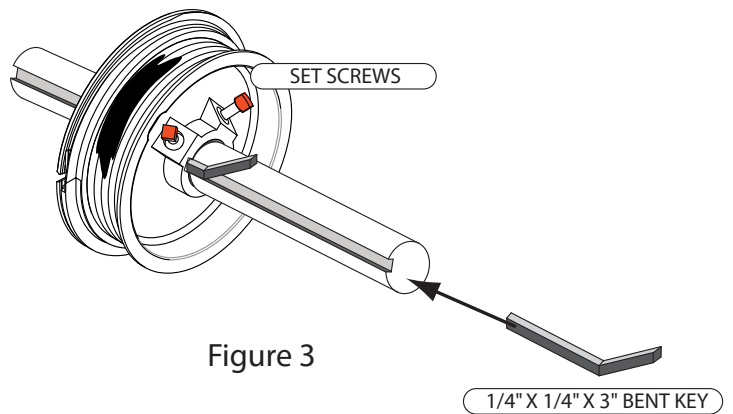

Offset Trolley Operator Application and Installation

USE ON COMMERCIAL DOORS THAT HAVE AN EVEN NUMBER OF CENTER STILES (2, 4, 6, etc.)

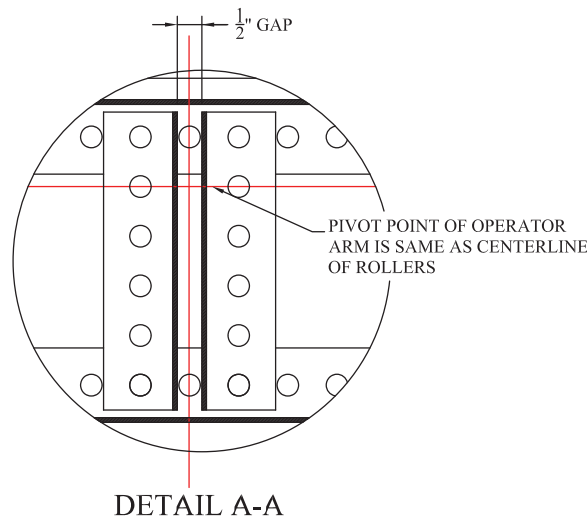
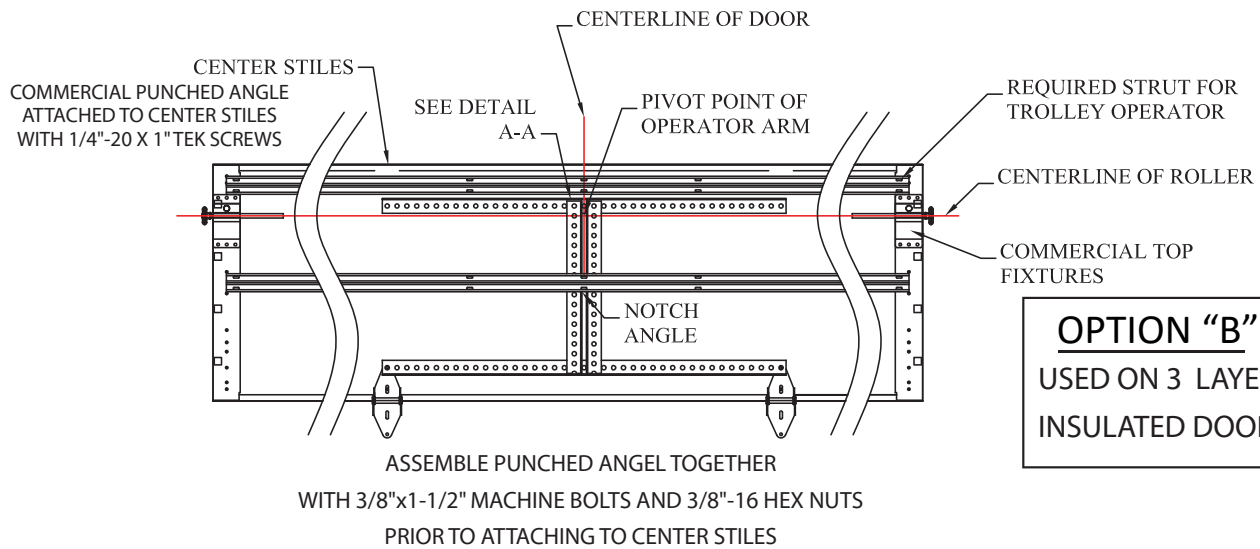
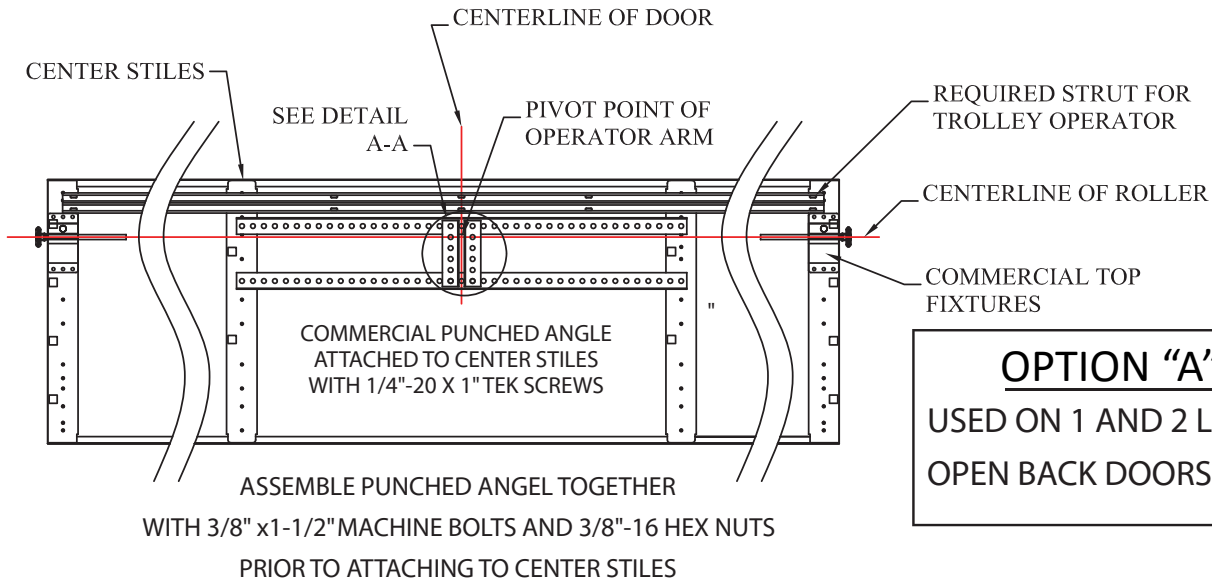

Amarr Manufactured Aluminum Full View Amarr 3552, AX3592 & Vista VI1000

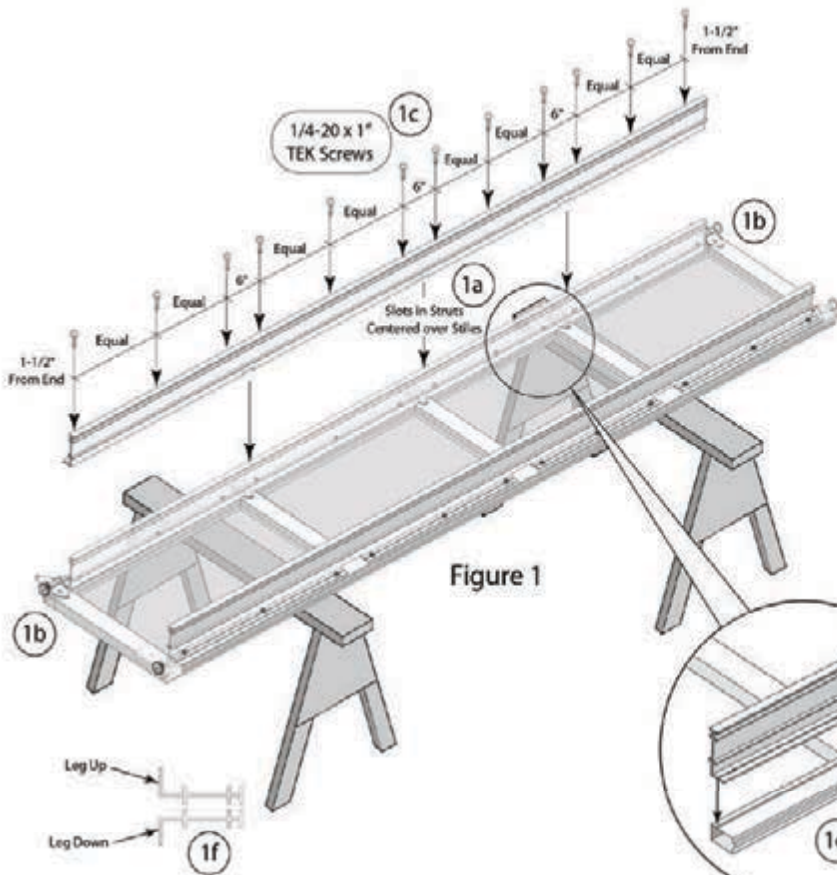

Figure 1

Note A: These instructions begin following Step 8, page 10 of the Basic Commercial Instructions.

Note B: For Amarr 3552 & AX3592 doors wider than 16'2"

- All sections will require (1) Aluminum Strut, attached at the top of each section.
- Bottom sections will require (1) Aluminum Strut, attached at the top of the section, leg up and (1) Aluminum Strut, attached at the bottom of the section, leg down (see Figure 1f for leg up/down illustration).

Step 1: Place the bottom section on a pair of padded saw horses (Figure 1).

Step 2: Align the slots in the struts with the center stiles of the section (Figures 1a). The small groove in the struts should also be aligned directly over the matching groove in the section rail (Figure 1d, shown with rail cut-away for clarity).

Note C: For Single End Stile sections there should be 3" from the end of the struts to the end of the section (Figure 1b). For Double End Stile sections there should be 6" from the end of the struts to the end of the section.

Step 3: Fasten the struts to the section using 1/4-20 x 1" TEK Screws (Figure 1c).

- (1) TEK Screw should be used at each end stile
- (2) TEK Screws should be used at each Center Stile
- (1) TEK Screw should be used centered between each Stile

Note D: The TEK Screws should be installed in the pre-drilled holes located on the small groove as shown in Figure 1e.

Note E: Figure A shows strut installation on a bottom section. Strut installation will be the same for all intermediate and top sections but with only one strut at the top of the section.

Step 4: Resume installation of sections, as shown starting with Step 9, page 10 of the Basic Commercial Instructions, with the required Aluminium Struts installed.

IMPORTANT NOTICE

DAMAGE TO THE GARAGE DOOR DUE TO AN IMPROPERLY INSTALLED OR ADJUSTED ELECTRIC OPENER IS NOT COVERED BY AMARR'S WARRANTY.

ELECTRIC OPENER ATTACHMENT

When installing a garage door opener, the following applies:

1. The door springs must be in good working order and the door must be balanced (should be able to raise the door 1/2 way and have the door stay in place).
2. When used with a Trolley Operator, the top section of the door include a strut in order to reinforce the opener arm lift point.
3. Disconnect and/or remove all locks and pull ropes. Attempting to use the opener while door is locked will damage the garage door.

IMPORTANT NOTICE

YOUR DOOR MAY REQUIRE ADDITIONAL REINFORCEMENT TO MEET SPECIFIC WIND & LOAD REQUIREMENTS. AMARR RECOMMENDS THAT YOU CONTACT YOUR LOCAL BUILDING OFFICIAL FOR SPECIFIC WIND & LOAD REQUIREMENTS IN YOUR AREA. MANY AMARR DOORS HAVE ENGINEERING DRAWINGS TO MEET WIND & LOAD REQUIREMENTS. DOORS MUST BE ASSEMBLED PRECISELY AS SHOWN IN THE DRAWINGS. CONTACT AMARR IF WIND LOAD DRAWINGS AND STRUT SCHEDULES WERE NOT SUPPLIED WITH YOUR DOOR.

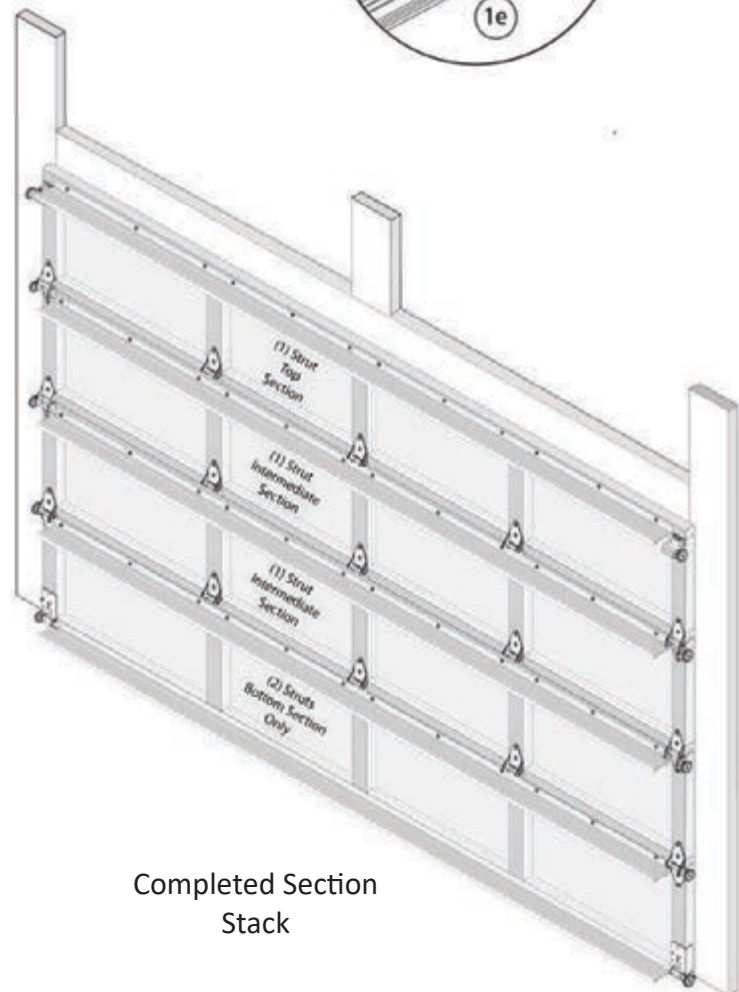
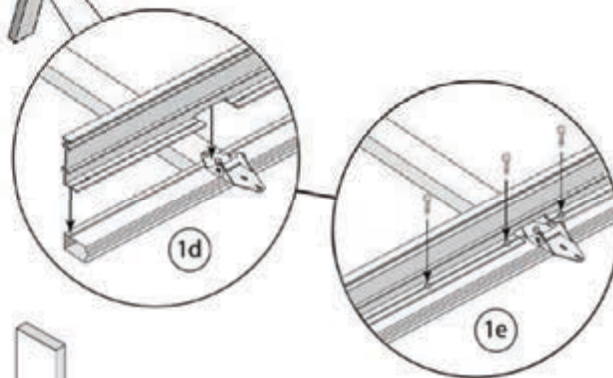

**Completed Section
Stack**

Amarr Manufactured Aluminum MultiView Amarr 3582 & Horizon HO1000

IMPORTANT NOTICE

DAMAGE TO THE GARAGE DOOR DUE TO AN IMPROPERLY INSTALLED OR ADJUSTED ELECTRIC OPENER IS NOT COVERED BY AMARR'S WARRANTY.

ELECTRIC OPENER ATTACHMENT

When installing a garage door opener, the following applies:

1. The door springs must be in good working order and the door must be balanced (should be able to raise the door 1/2 way and have the door stay in place).
2. When used with a Trolley Operator, the top section of the door include a strut in order to reinforce the opener arm lift point.
3. Disconnect and/or remove all locks and pull ropes. Attempting to use the opener while door is locked will damage the garage door.

IMPORTANT NOTICE

YOUR DOOR MAY REQUIRE ADDITIONAL REINFORCEMENT TO MEET SPECIFIC WIND & LOAD REQUIREMENTS. AMARR RECOMMENDS THAT YOU CONTACT YOUR LOCAL BUILDING OFFICIAL FOR SPECIFIC WIND & LOAD REQUIREMENTS IN YOUR AREA. MANY AMARR DOORS HAVE ENGINEERING DRAWINGS TO MEET WIND & LOAD REQUIREMENTS. DOORS MUST BE ASSEMBLED PRECISELY AS SHOWN IN THE DRAWINGS. CONTACT AMARR IF WIND LOAD DRAWINGS AND STRUT SCHEDULES WERE NOT SUPPLIED WITH YOUR DOOR.

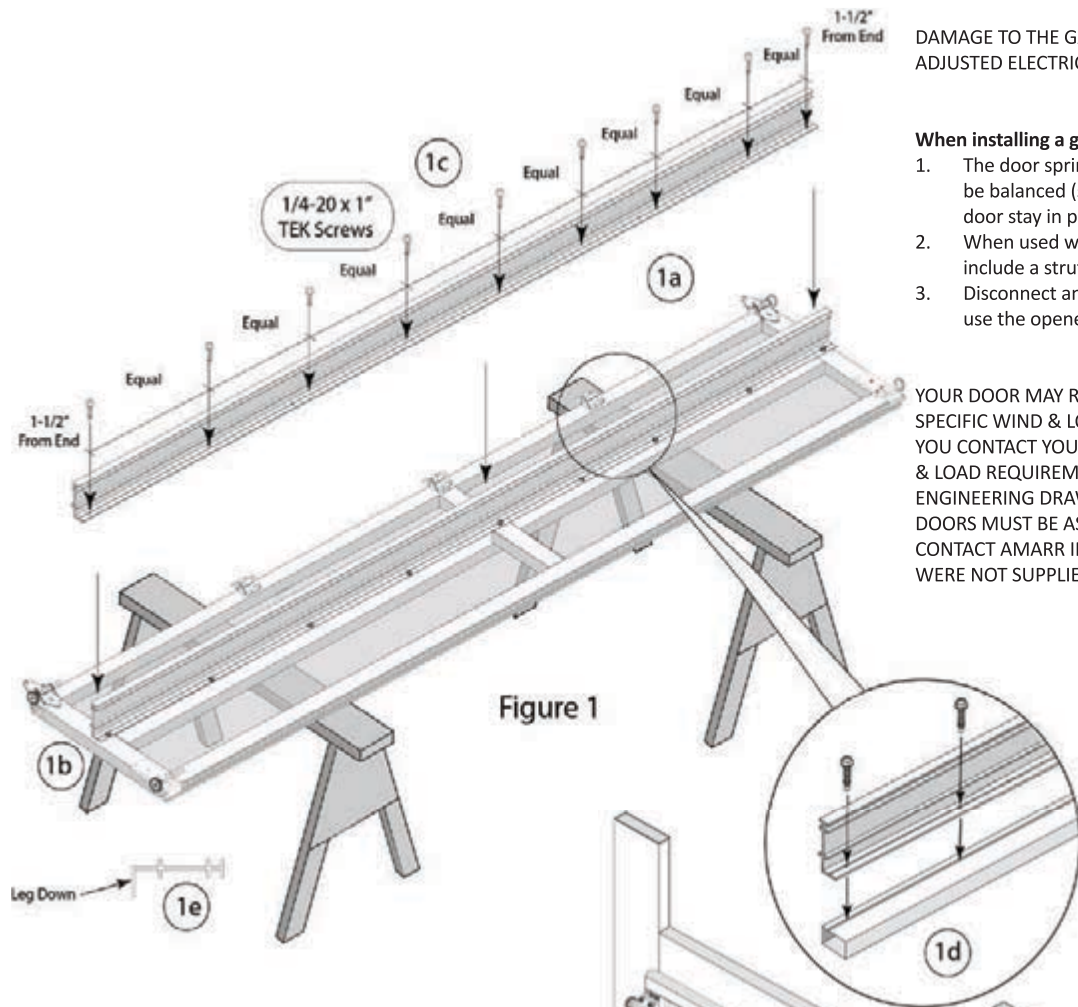

Figure 1

Note A: These instructions begin following Step 8, page 10 of the of Basic Commercial Instructions.

Note B: For Model 3582 doors 15' wide and wider :

- All sections will require (1) Aluminum Strut, attached leg down, at the middle of each section (see Figure 1e for leg down illustration).

Step 1: Place the bottom section on a pair of padded saw horses (Figure 1b).

Step 2: Align the the struts with the center rail of the section (Figure 1a). The small groove in the struts should also be aligned directly over the matching groove in the section rail (Figure 1d, shown with rail cut-away for clarity).

Step 3: Fasten the struts to the section using 1/4-20 x 1" TEK Screws (Figure 1c).

- (1) TEK Screw should be used at each End stile
- (2) TEK Screws should be used at each Double End Stile
- (1) TEK Screws should be used at each Center Stile
- TEK Screw(s) should be used, spaced evenly between each Stile (no more than 24" on center)

Note C: The TEK Screws should be installed in the pre-drilled holes located on the small groove as shown in Figure 1d.

Note D: Figure A shows strut installation on a bottom section. Strut installation will be the same for all intermediate and top sections,

Note E: The strut in the center of the top section is suitable to use as reinforcement for Trolley Operators.

Step 4: Resume installation of sections, as shown starting with Step 9, page 10 of the Basic Commercial Instructions, with the required Aluminium Struts installed.

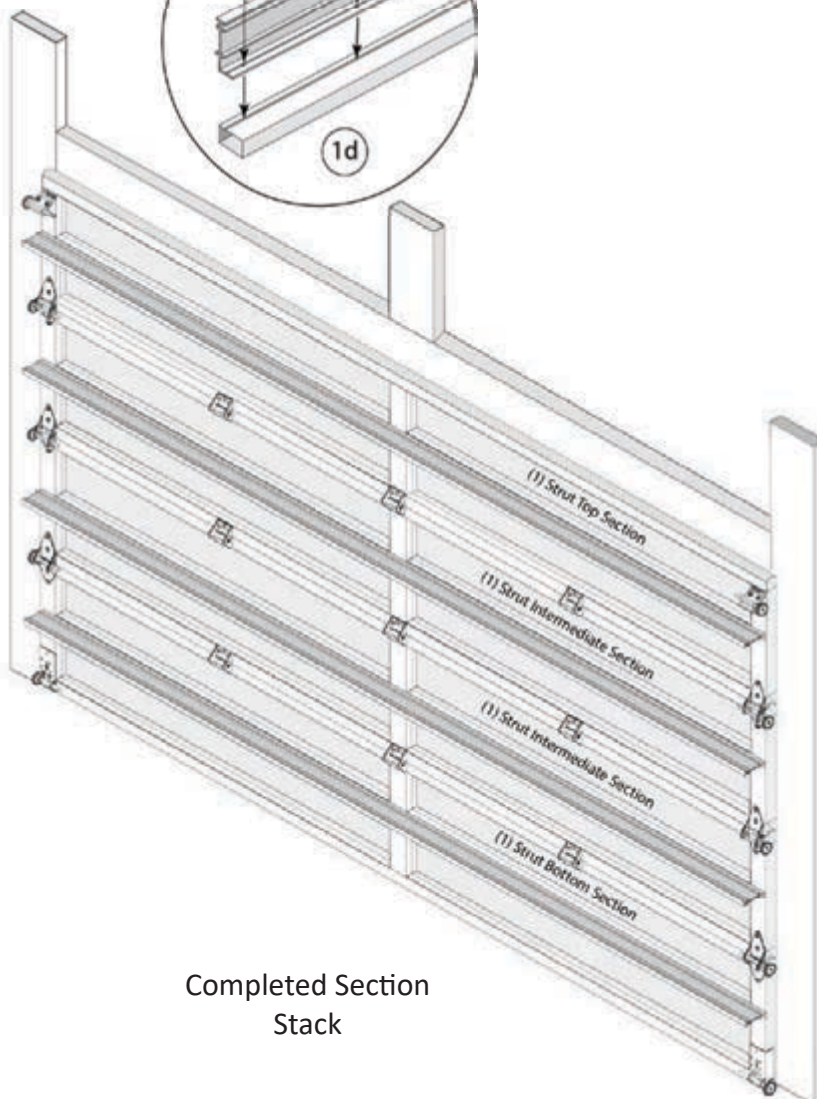

Completed Section
Stack



Since 1951, we have successfully raised the standards of quality, value, and dependability in our industry. Today, with the same promise of individual attention and great value for all our customers, we remain committed to offering product and services that raise those standards even higher.

Amarr Company

165 Carriage Court

Winston-Salem, NC 27105

800.503.DOOR

www.amarr.com

Door Specifications and Technical data subject to change without notice.

Sectional door products from Amarr Company may be the subject of one or more U.S. and/or foreign, issued and/or pending, design and/or utility patents.

Amarr, Classica, and Heritage as word and logos are trademarks owned by Amarr Company.

©ASSA ABLOY



Visit amarr.com for additional information on Amarr garage doors, garage door openers and garage door accessories.

